

# MINARC M 223 AUTO GM, MINARC M 223P AUTO GM

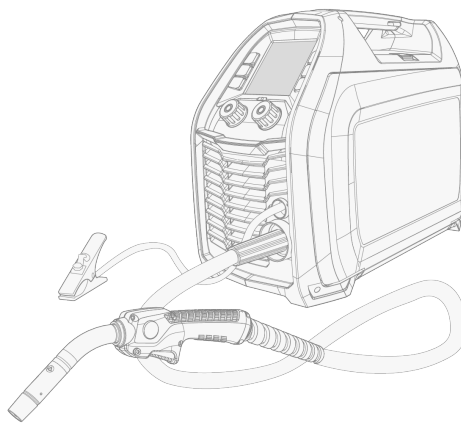

## CONTENTS

<b>1. General</b>	<b>4</b>
1.1 Welding safety	6
1.2 Equipment description	7
1.3 Minarc M devices	8
1.3.1 Wire feed mechanism	9
1.4 Flexlite GXe 223GMM3 welding torch	11
<b>2. Installation</b>	<b>12</b>
2.1 Installing and changing feed roll	13
2.2 Installing and changing wire guide tubes	15
2.3 Installing and changing wire and spool (200 mm)	16
2.4 Installing and changing wire spool (100 mm)	20
2.5 Installing and changing wire liner (Flexlite GXe 223GMM3)	22
2.5.1 Removing wire liner	22
2.5.2 Installing steel wire liner	24
2.5.3 Installing DL Chili wire liner	26
2.6 Connecting welding torch (Flexlite GXe 223G3)	29
2.7 Installing additional gun handle	30
2.8 Installing gas bottle and testing gas flow	31
2.9 Installing equipment on cart (optional)	34
2.10 Attaching carrying strap (optional)	37
<b>3. Operation</b>	<b>38</b>
3.1 Preparing welding device for use	39
3.2 Minarc M control panel	40
3.2.1 Control panel display items	41
3.2.2 Base settings for 1-MIG and Pulse MIG	43
3.2.3 Main welding parameters	44
3.2.4 Additional welding parameters	46
3.2.5 Memory channels	49
3.2.6 Warning and error indicators	50
3.2.7 Welding view	50
3.2.8 Weld data	51
3.2.9 Wire inch	51
3.2.10 Gas test	51
3.3 Additional guidance to functions and features	52
3.3.1 1-MIG	52
3.3.2 Pulse	52
3.3.3 Trigger logic functions	52

---

3.4 Changing welding polarity .....	54
3.5 Lifting Minarc M equipment .....	56
3.6 Troubleshooting .....	57
3.6.1 Error codes .....	58
<b>4. Maintenance .....</b>	<b>60</b>
4.1 Assembling welding torch (Flexlite GXe 223GMM3) .....	61
4.2 Changing welding torch (Flexlite GXe 223GMM3) .....	62
4.3 Daily, periodic and annual maintenance .....	64
4.4 Disposal .....	66
<b>5. Technical data .....</b>	<b>67</b>
5.1 Minarc M devices .....	68
5.2 Flexlite GXe 223GMM3 welding torch .....	74
5.3 Wire feeder consumables .....	75
5.3.1 Minarc M 223 wire feeder consumables .....	75
5.3.2 Minarc M 223P wire feeder consumables .....	76
5.4 Minarc M welding program work packs .....	77
5.5 Minarc M ordering info .....	80
5.6 Minarc M control panel symbols and icons summary .....	81

## 1. GENERAL

These instructions describe the use of Kemppi's Minarc M 223 and Minarc M 223P welding devices designed for professional use in MIG/MAG welding.

The equipment consists of a power source with an integrated wire feeder, and an optional cart. The Minarc Cooler 05 cooling unit can be used with Minarc M 223P with 220...240 V supply voltage.

Both devices include manual and automatic 1-MIG welding processes. Pulse welding is possible with Minarc M 223P with 220...240 V supply voltage.

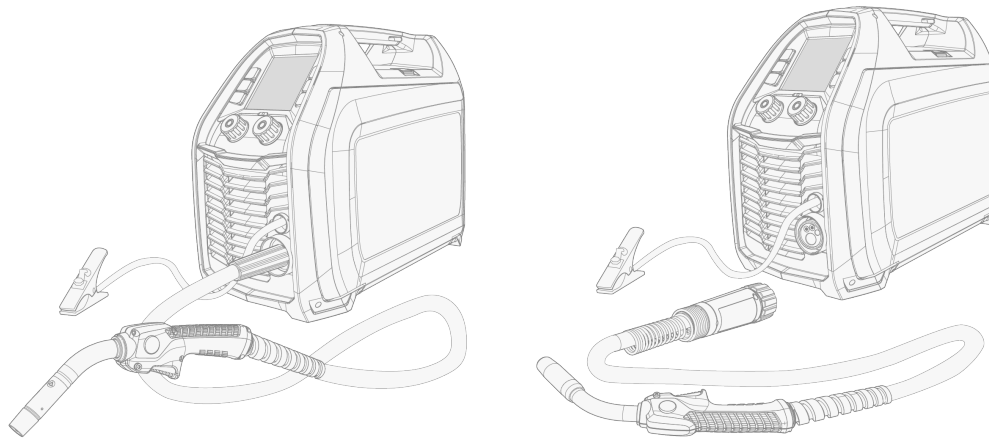



### Important notes

Read the instructions through carefully.

Items in the manual that require particular attention in order to minimize damage and harm are indicated with the below symbols. Read these sections carefully and follow their instructions.

 *Note: Gives the user a useful piece of information.*

 *Caution: Describes a situation that may result in damage to the equipment or system.*

 *Warning: Describes a potentially dangerous situation. If not avoided, it will result in personal damage or fatal injury.*

[General notices](https://kemp.cc/ud/notices) 

<https://kemp.cc/ud/notices>

[EULA \(End User License Agreement\)](https://kemp.cc/ud/eula) 

<https://kemp.cc/ud/eula>

[Warranty](https://kemp.cc/ud/warranty) 

<https://kemp.cc/ud/warranty>

## DISCLAIMER

While every effort has been made to ensure that the information contained in this guide is accurate and complete, no liability can be accepted for any errors or omissions. Kempfi reserves the right to change the specification of the product described at any time without prior notice. Do not copy, record, reproduce or transmit the contents of this guide without prior permission from Kempfi.

The source language for this document is English. All other language versions available are either professional human translations or advanced machine translations. Any feedback regarding translation terminology can be sent to [userdoc@kempfi.com](mailto:userdoc@kempfi.com).

## 1.1 WELDING SAFETY

Welding is always classified as hot work, and welding equipment typically contains high-voltage circuits. If you are not familiar with welding and welding principles, it is recommended that you acquire welding training or professional guidance before commencing welding. The welding equipment mentioned in this manual is intended for professional use in an industrial environment.

 *For your own safety, and that of your working environment, pay particular attention to the safety instructions delivered with the equipment.*

You can also access and download the safety instructions by using these links:

- [Safety](https://kemp.cc/safety/general)  
(<https://kemp.cc/safety/general>)
- [Personal protection](https://kemp.cc/safety/ppe)  
(<https://kemp.cc/safety/ppe>)
- [Welding guns and torches](https://kemp.cc/safety/torches)  
(<https://kemp.cc/safety/torches>)

## 1.2 EQUIPMENT DESCRIPTION

### Minarc M device models

- Minarc M 223 Auto GM (220 A)
  - >> Generator-compatible and multi-voltage
  - >> Standard device with support for manual MIG and automatic 1-MIG processes
- Minarc M 223P Auto GM (220 A)
  - >> Generator-compatible and multi-voltage
  - >> Pulse device with support for manual MIG, automatic 1-MIG and pulse MIG processes (pulse welding only with 220...240 V supply voltage)

The Minarc M device models have a 2-roll wire feed mechanism. The maximum wire spool diameter is 200 mm.

For the Minarc M device part descriptions, refer to "Minarc M devices" on the next page.

### Cooling unit (optional)

- Minarc Cooler 05
- Can be used only with Minarc M 223P with 220...240 V supply voltage

For information on the Minarc Cooler 05 cooling unit, refer to [Kempfi Userdoc](#).

### MIG welding torches

- Flexlite GXe 223GMM3
  - >> Fixed welding torch on Minarc M 223
  - >> Technical data and operating instructions are included in this operating manual
- Flexlite GXe 223G3
  - >> Included in the delivery of Minarc M 223P
  - >> For technical data and operating instructions, refer to [Kempfi Userdoc](#)

Other Flexlite GXe welding torch models with a Euro connector are compatible with Minarc M 223P (refer to [Kempfi Userdoc](#)).

### Welding programs

- Welding program work pack (factory-installed)

For more information, refer to "Minarc M welding program work packs" on page 77.

### Optional accessories

- 2-wheel carts

For more information on optional accessories, contact your local Kempfi dealer.

## EQUIPMENT IDENTIFICATION

### Serial number

Serial number of the device is marked on the rating plate or in another distinctive location on the device. It is important to make correct reference to the serial number of the product when ordering spare parts or making repairs for example.

### Quick Response (QR) code

The serial number and other device-related identification information may also be saved in the form of a QR code (or a barcode) on the device. Such code can be read by a smartphone camera or with a dedicated code reader device providing fast access to the device-specific information.

## 1.3 MINARC M DEVICES

### Front

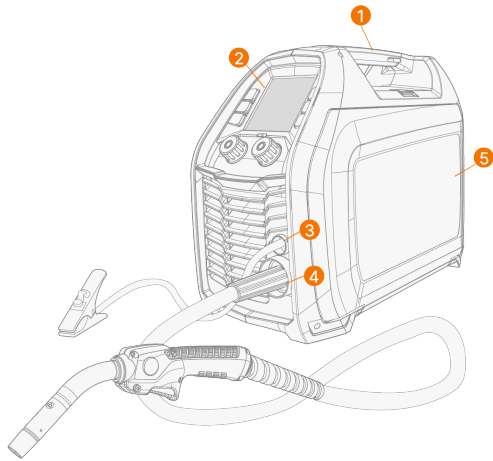

*Minarc M 223*

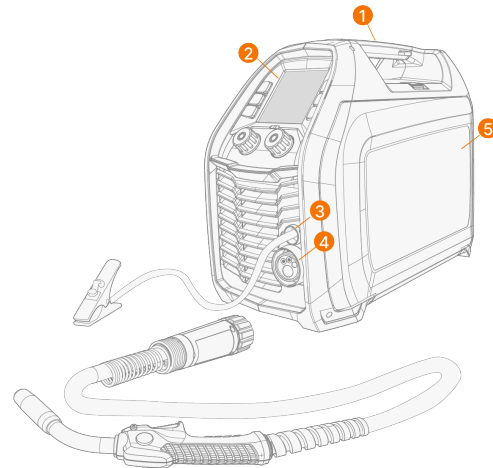

*Minarc M 223P*

1. Handle (also for mechanical lifting when the device is not installed on a cart)
2. Control panel
3. Earth return cable (pre-installed)
4. Minarc M 223: Fixed welding torch / Minarc M 223P: Euro connector
5. Wire feed cabinet hatch

### Rear

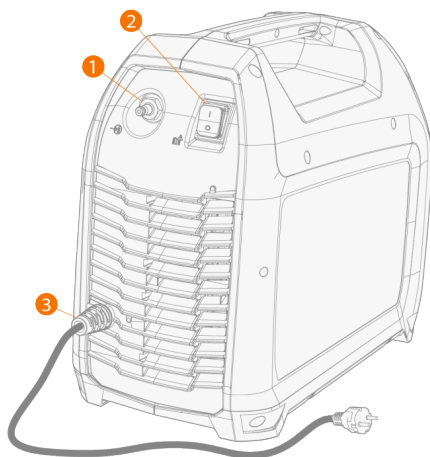

1. Shielding gas hose connector
2. Power switch
3. Mains cable

### Inside wire feed cabinet

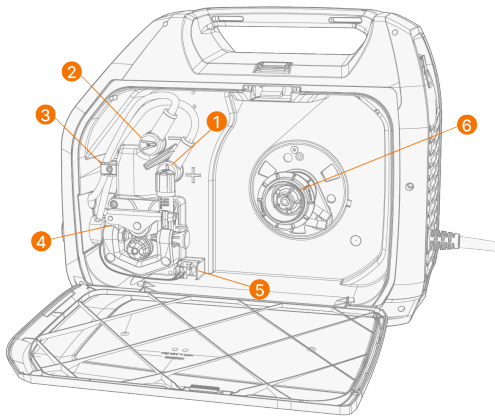

1. Polarity terminal, plus (+)
2. Polarity terminal, minus (-)
3. Cable retaining clamp
4. Wire feed mechanism (refer to "Wire feed mechanism" below)
5. Welding torch trigger cable connector
6. Wire spool hub

### 1.3.1 WIRE FEED MECHANISM

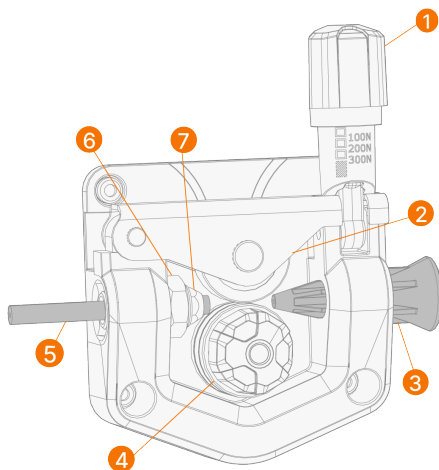

1. Pressure handle
2. Fixed pressure roll
3. Inlet guide tube
4. Feed roll and feed roll mounting cap
5. Minarc M 223P: Outlet guide tube
6. Retaining nut
  - >> Minarc M 223: Holds the fixed welding torch in place
  - >> Minarc M 223P: Attaches the Euro connector
7. Wire liner end nut.

For changing the feed roll, refer to "Installing and changing feed roll" on page 13.

For changing the wire guide tubes, refer to "Installing and changing wire guide tubes" on page 15.

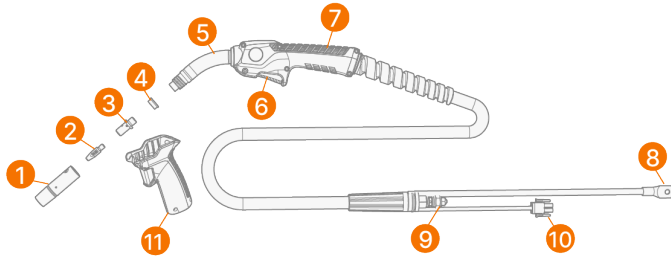

## 1.4 FLEXLITE GXE 223GMM3 WELDING TORCH

The Flexlite GXe 223GMM3 welding torch consists of:



1. Gas nozzle
2. Contact tip
3. Contact tip adapter / gas diffuser
4. Insulating ring
5. Torch neck
6. Trigger switch
7. Handle
8. Welding current cable
9. Welding torch retaining nut and wire liner end nut
10. Welding torch trigger cable
11. Additional gun handle

## 2. INSTALLATION

-  *Do not connect the equipment to the mains before the installation is complete.*
-  *Do not modify the welding equipment in any way, except for the changes and adjustments covered in the manufacturer's instructions.*
-  *Place the machine on a horizontal, stable and clean ground. Protect the machine from rain and direct sunshine. Check that there is enough space for cooling air circulation in the machine vicinity.*

### **Before installation**

- Make sure to acknowledge and follow the local and national requirements regarding installation and use of high voltage units.
- Check the contents of the packages and make sure the parts are not damaged.
- Before you install the power source on site, see the requirements for the mains cable type and fuse rating.

### **Distribution network**

-  *This Class A equipment is not intended for use in residential locations where the electrical power is provided by the public low-voltage supply system. There can be potential difficulties in ensuring electromagnetic compatibility in those locations, due to conducted as well as radiated radio-frequency disturbances. However, Minarc M complies with IEC 61000-3-12 and can also be connected to public low-voltage systems.*

## 2.1 INSTALLING AND CHANGING FEED ROLL

Minarc M feed rolls have two grooves and can be turned over to select the correct groove for the filler wire diameter. The device is equipped with a standard feed roll with V-grooves for 0.6 mm and 0.8–0.9 mm filler wires. For other filler wire diameters and types, change the feed roll to a suitable one. Select the feed roll according to the tables in "Wire feeder consumables" on page 75.

 *The fixed pressure roll does not require replacement.*

1. Open the wire feed cabinet hatch.
2. Release the pressure handle and fixed pressure roll.

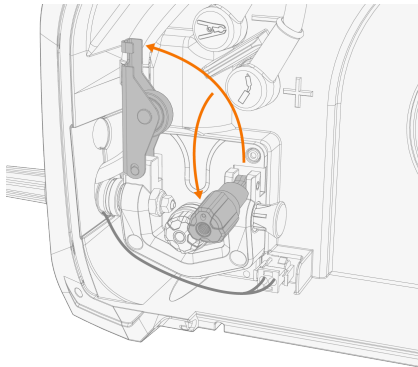

3. Remove the feed roll mounting cap by turning and pulling it.

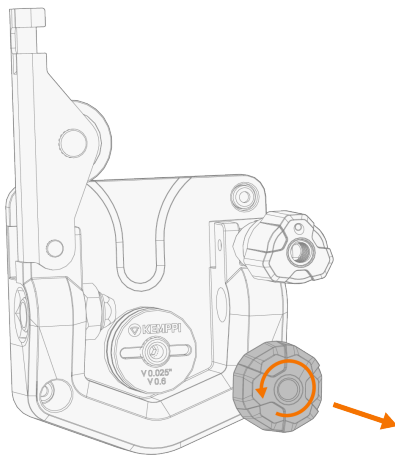

4. Remove the feed roll.
5. Turn the feed roll over and reinstall it or change it to another one. Align the cut on the bottom with the pin on the drive shaft.

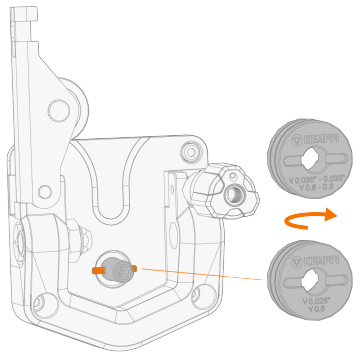

6. Reattach the mounting cap to lock the feed roll in place.
7. Close the fixed pressure roll and pressure handle.
8. Close the wire feed cabinet hatch.

## 2.2 INSTALLING AND CHANGING WIRE GUIDE TUBES

Change the wire guide tubes when the filler wire diameter or material changes. Select the wire guide tubes according to the tables in "Wire feeder consumables" on page 75.

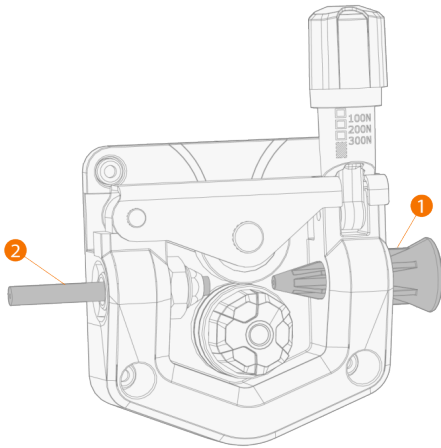

1. Inlet guide tube
2. Minarc M 223P: Outlet guide tube

 *When changing the outlet guide tube, the welding torch must be detached.*

### To change the wire guide tubes:

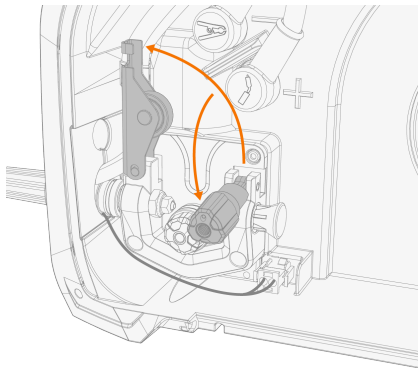

1. Release the pressure handle and fixed pressure roll.



2. Remove the filler wire from the system.
3. Pull out the inlet guide tube (1) and insert a new one in its place.
4. Minarc M 223P: Pull out the outlet guide tube (2) and insert a new one in its place.
5. Close the pressure handle and fixed pressure roll.

## 2.3 INSTALLING AND CHANGING WIRE AND SPOOL (200 MM)

This section describes how to install and change wire and a 200 mm spool. The spool hub for a 200 mm spool is factory installed on Minarc M machines. For instructions on installing a 100 mm spool, refer to "Installing and changing wire spool (100 mm)" on page 20.

-  *Minarc M 223P: Install the welding torch to the device before installing the wire spool.*
-  *When changing the wire spool, remove the remaining filler wire from the welding torch and wire feed mechanism before removing the wire spool.*
-  *Always ensure that the feed roll is suitable for the filler wire (diameter and material) in question. For more information, refer to "Wire feeder consumables" on page 75.*

### To remove the wire spool:

1. Open the wire feed cabinet hatch.
2. Loosen and remove the spool fastener and remove the wire spool.

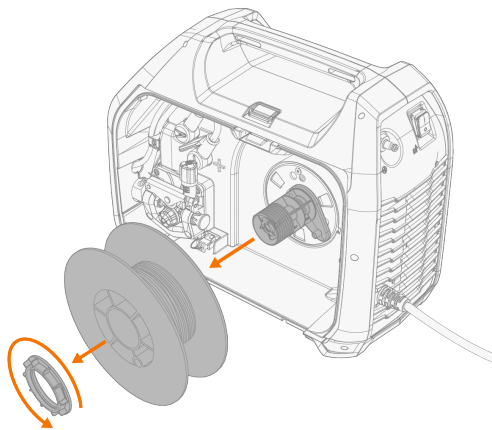

### To install a new wire spool:

1. Insert the wire spool onto the spool hub. Secure the wire spool in place by inserting and tightening the spool fastener.
-  *Ensure that the wire spool is facing the right direction.*

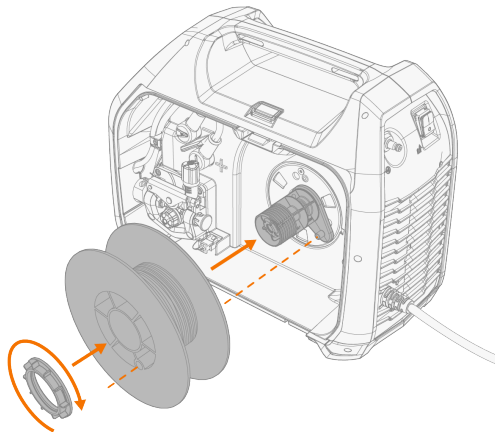

2. If needed, adjust the spool brake by turning the spool brake tightening knob in the center of the spool hub.

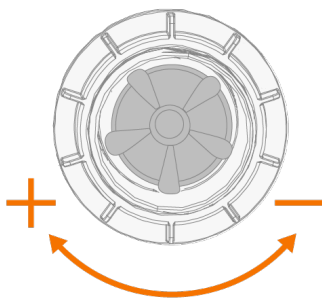
**To install the filler wire:**

1. Release the filler wire end from the spool and cut off any deformed section so that the end is straight.

 *Ensure that the filler wire does not spill from the spool when it is released.*

2. File the tip of the filler wire smooth.

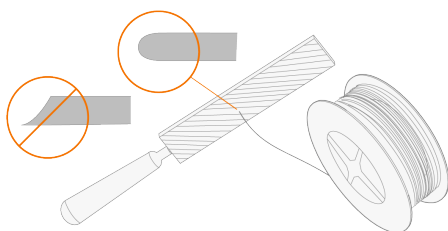

 *Sharp edges on the filler wire tip may damage the wire liner.*

3. Release the pressure handle and fixed pressure roll.

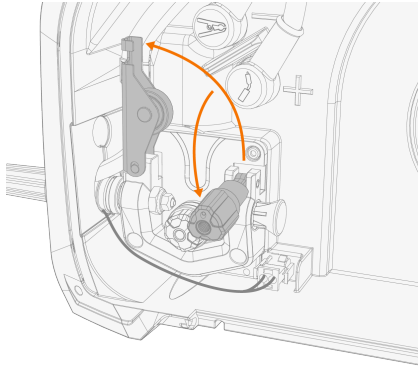

4. Push the filler wire by hand into the welding torch so that the wire reaches the wire liner.

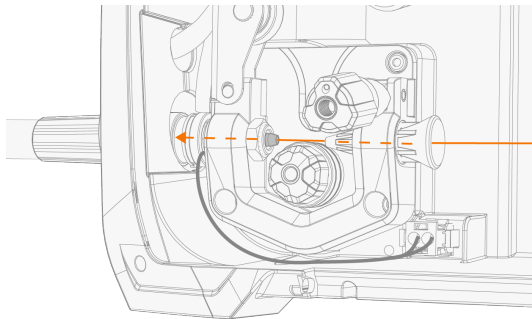

5. Close the fixed pressure roll.
6. Adjust the pressure with the pressure adjustment wheel.

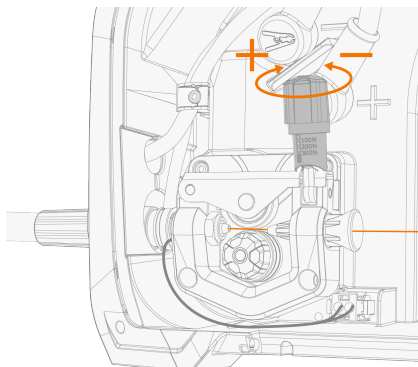

The graduated scales on the pressure handle indicate the applied pressure. Adjust the pressure according to the table below.

Filler wire material	Feed roll profile	Feed roll profile symbol	Filler wire diameter (mm)	Adjustment (x100N)
Fe/Ss solid	V-groove	V	0.6/0.8-0.9	1.5-2.0
			1.0/1.2	2.0-2.5
MC/FC	V-groove, knurled	V≡	1.0/1.2	1.0-2.0

Al	U-groove	U	1.0	0.5–1.0
			1.2	1.0–1.5

**⚠** *Excessive pressure flattens the filler wire and may damage coated or cored filler wires. Excessive pressure also unnecessarily wears the feed roll and increases gearbox load.*

7. Press and hold the wire inch button to drive the filler wire into the welding torch. Stop when the wire reaches the welding torch's contact tip.

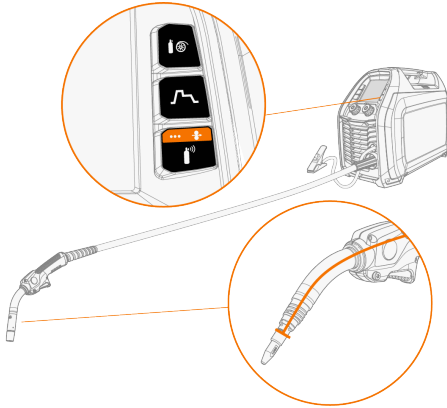



**⚠** *Watch out for the wire when it reaches the contact tip and exits the welding torch.*

Before welding, ensure that the welding parameters and settings conform to your welding setup.

## 2.4 INSTALLING AND CHANGING WIRE SPOOL (100 MM)

This section describes how to install and change a 100 mm spool. For instructions on installing and changing wire and 200 mm spool, refer to "Installing and changing wire and spool (200 mm)" on page 16.



-  *Minarc M 223P: Install the welding torch to the device before installing the wire spool.*
-  *When changing the wire spool, remove the remaining filler wire from the welding torch and wire feed mechanism before removing the wire spool.*
-  *Always ensure that the feed roll is suitable for the filler wire (diameter and material) in question. For more information, refer to "Wire feeder consumables" on page 75.*

### To remove the standard spool hub:

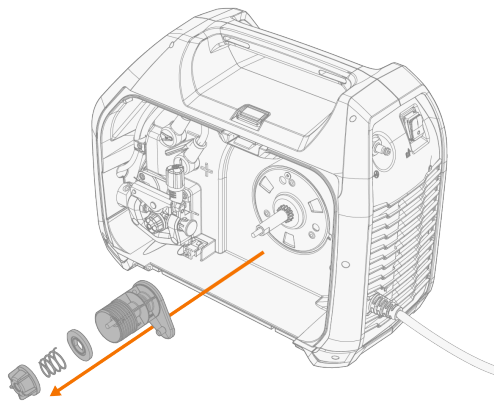
1. Open the wire feed cabinet hatch.
2. If not already, remove the wire spool (refer to "Installing and changing wire and spool (200 mm)" on page 16).
3. Loosen the spool hub fastener and remove the spool hub.



### To install a 100 mm wire spool:

1. Insert the wire spool, spring friction plate, spring and spool hub fastener onto the spool hub. Secure the wire spool in place by tightening the spool hub fastener.
-  *Ensure that the wire spool is facing the right direction.*
  -  *Ensure that the grooved side of the spring friction plate faces outward.*

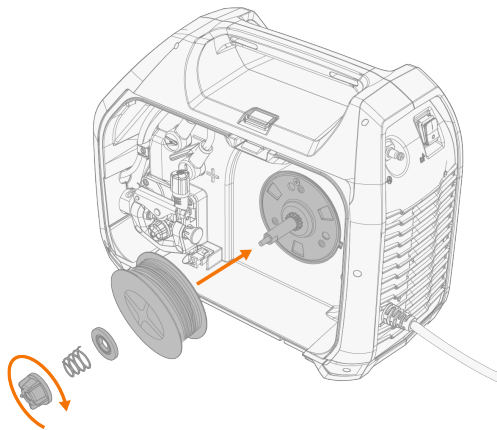

2. If needed, adjust the spool brake by turning the spool brake tightening knob in the center of the spool hub.

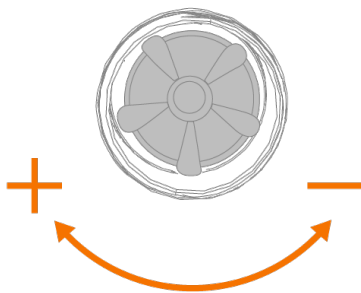

To install the filler wire, refer to "Installing and changing wire and spool (200 mm)" on page 16.

## 2.5 INSTALLING AND CHANGING WIRE LINER (FLEXLITE GXE 223GMM3)



The Flexlite GXe 223GMM3 and 223G3 welding torches are delivered with the steel wire liner pre-installed. Refer to this section when the wire liner needs to be changed on the Flexlite GXe 223GMM3 welding torch. For instructions on changing the wire liner on the Flexlite GXe 223G3 welding torch, refer to [Kempfi User-doc](#).

The wire liner is a consumable part, which needs to be changed if worn and when the filler wire material changes.

For removing the old wire liner, refer to "Removing wire liner" below.

For installing the steel wire liner, refer to "Installing steel wire liner" on page 24.

For installing the DL Chili wire liner, refer to "Installing DL Chili wire liner" on page 26.

-  *Turn off the welding device before wire liner replacement.*
-  *If you change the filler wire to a different diameter or material, change also the feed roll and the inlet guide tube in the wire feed system accordingly.*
-  *The filler wire must be removed before changing the wire liner. Always read the instructions delivered with the replacement wire liner as well.*

### 2.5.1 REMOVING WIRE LINER

This section describes how to remove the old wire liner. The method is the same for both steel and DL Chili wire liners.

Tools needed:



1. Straighten the welding torch cable.

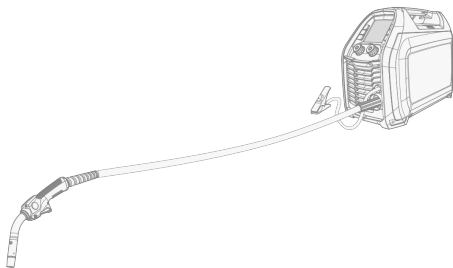

2. Release the pressure handle and the fixed pressure roll.

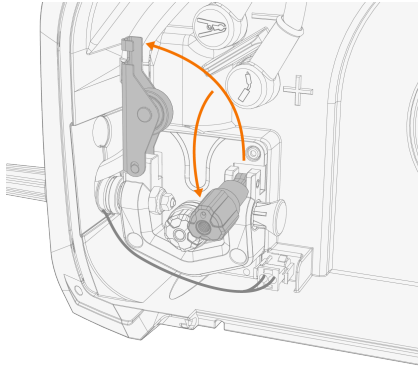

3. Remove the wire spool, and pull the filler wire out of the wire feeder and welding torch (refer to "Installing and changing wire and spool (200 mm)" on page 16).
4. Remove the feed roll and the inlet guide tube.

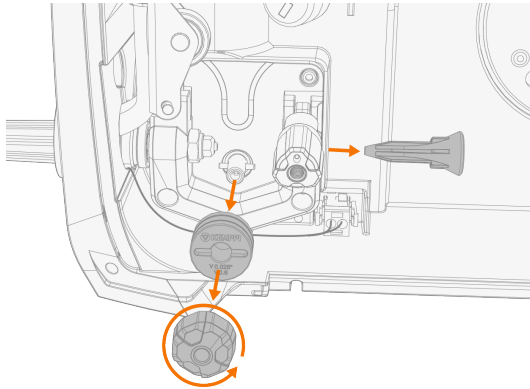

5. Remove the wire liner end nut.

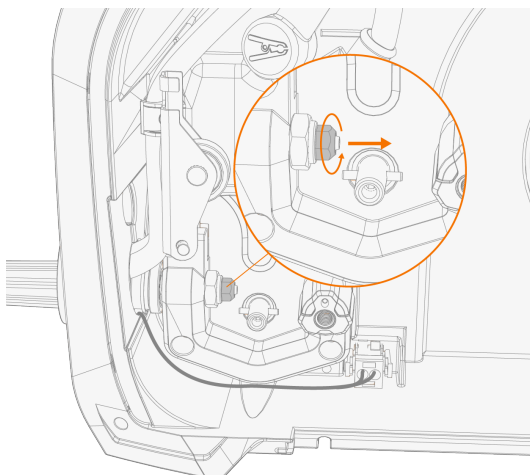

6. Remove the old wire liner by guiding the wire liner end (with the retainer cone) through the inlet guide tube aperture.

 *If you still plan to use the same wire liner later, make sure not to damage the wire liner at this stage.*

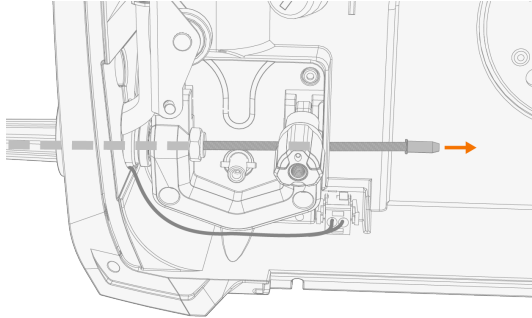

## 2.5.2 INSTALLING STEEL WIRE LINER

Tools needed:

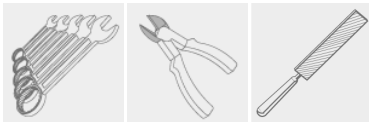

1. Remove the gas nozzle, contact tip and contact tip adapter from the welding torch (refer to "Assembling welding torch (Flexlite GXe 223GMM3)" on page 61).
2. Feed the new wire liner through the inlet guide tube aperture until it comes out at the welding torch end.

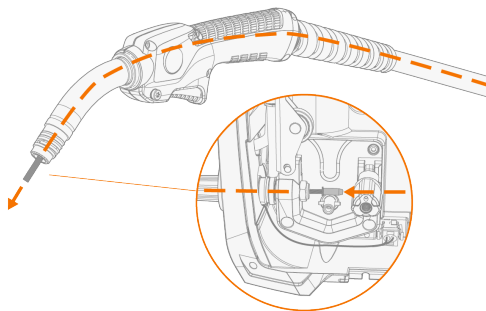

3. Insert the wire liner end nut and tighten it in place.

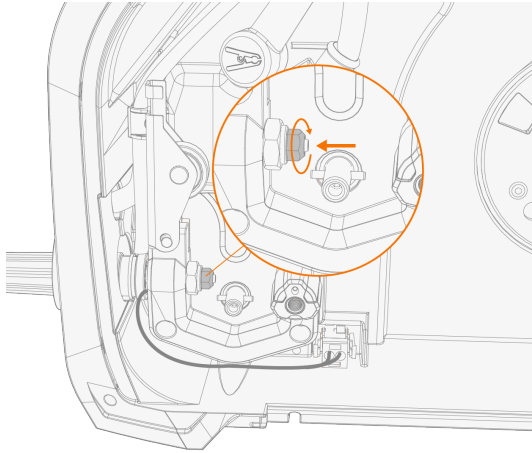

4. Cut the wire liner leaving 10 mm of excess wire liner measured from the insulating ring.

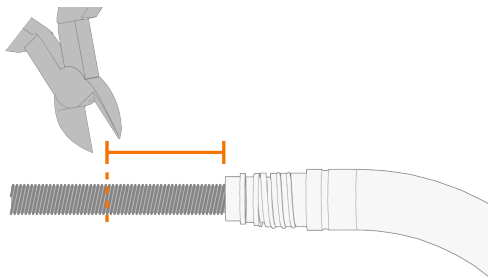

5. File the end of the wire liner.

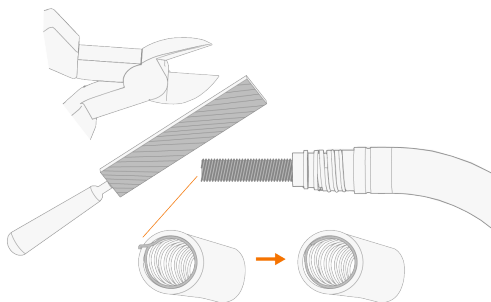

 *Don't leave any rough, inward edges that could potentially damage the filler wire.*

6. Reinstall the contact tip adapter, contact tip and gas nozzle.
7. Reinstall the feed roll and inlet guide tube (refer to "Installing and changing feed roll" on page 13 and "Installing and changing wire guide tubes" on page 15).
8. Reinstall the wire spool (refer to "Installing and changing wire and spool (200 mm)" on page 16).

### 2.5.3 INSTALLING DL CHILI WIRE LINER

Tools needed:

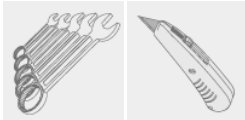

1. Remove the gas nozzle and contact tip from the welding torch (refer to "Assembling welding torch (Flexlite GXe 223GMM3)" on page 61).
2. Feed the new wire liner through the inlet guide tube aperture into the welding torch until it stops at the contact tip adapter.

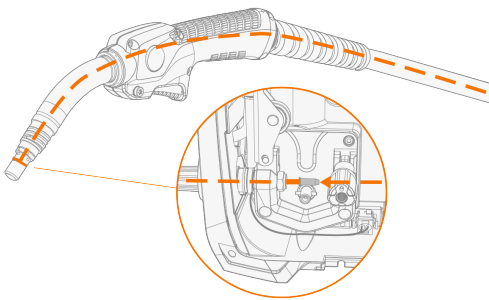

3. Measure 10 mm of the wire liner from the end nut and mark the point.

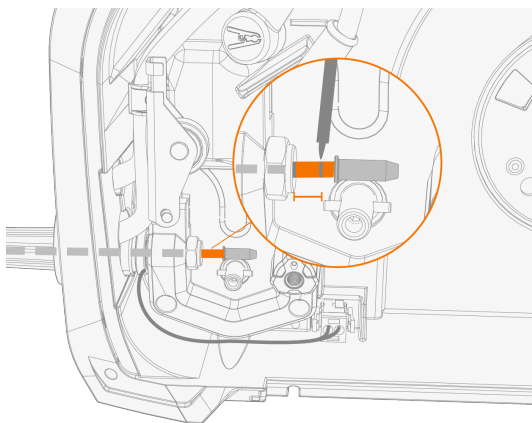

4. Pull the wire liner temporarily back out and cut it at the marked point.

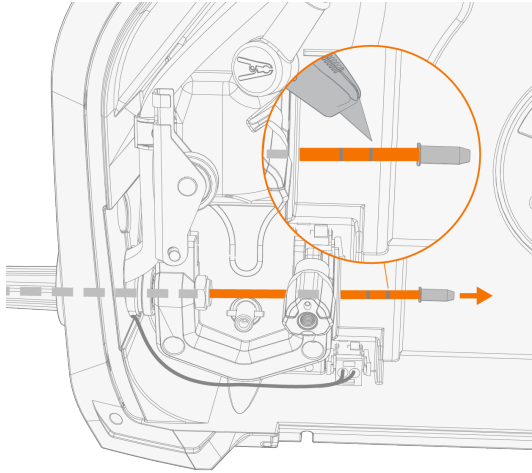

5. Remove the retainer cone from the cut piece of the wire liner and install it onto the end of the shortened wire liner. Ensure that the wire liner goes all the way into the tip of the retainer cone. Tighten the cone.

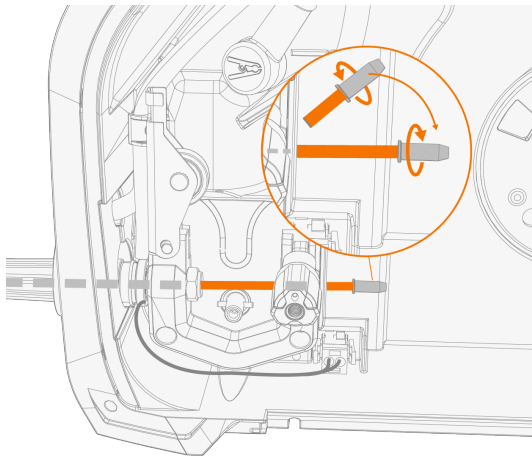

6. Feed the wire liner into the welding torch until it stops at the contact tip adapter.
7. Insert the wire liner end nut and tighten it in place.

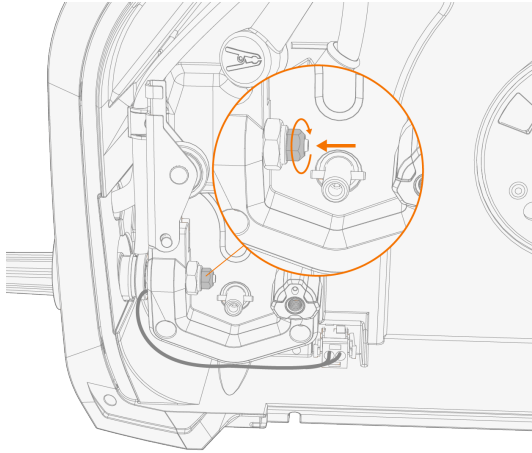

8. Reinstall the contact tip and gas nozzle.
9. Reinstall the feed roll and inlet guide tube (refer to "Installing and changing feed roll" on page 13 and "Installing and changing wire guide tubes" on page 15).
10. Reinstall the wire spool (refer to "Installing and changing wire and spool (200 mm)" on page 16).

## 2.6 CONNECTING WELDING TORCH (FLEXLITE GXE 223G3)

Minarc M 223P is delivered with the Kemppi Flexlite GXe 223G3 welding torch. For the operating instructions, refer to [Kemppi Userdoc](#).

 Always check that the wire liner, contact tip and gas nozzle are suitable for the job.

1. Push the welding torch connector into the Euro connector and hand-tighten the collar.

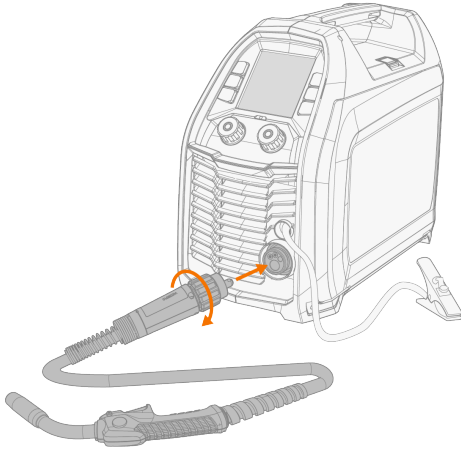

2. If your setup includes a water-cooled torch, connect the cooling liquid hoses to the cooling unit. The hoses are color-coded.

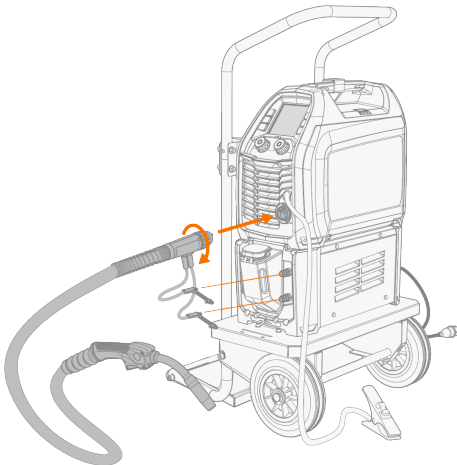

3. Install and load the filler wire as described in "Installing and changing wire and spool (200 mm)" on page 16.
4. Check the gas flow. Refer to "Installing gas bottle and testing gas flow" on page 31 for more information.

## 2.7 INSTALLING ADDITIONAL GUN HANDLE

1. Keeping the bottom of the grip handle pointing forward, fit the inside grooves of the grip handle over the screws on the torch.

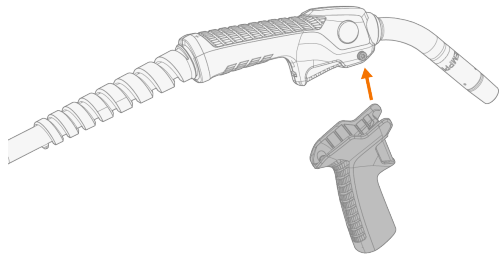

2. Pull the handle backward to lock it in position.

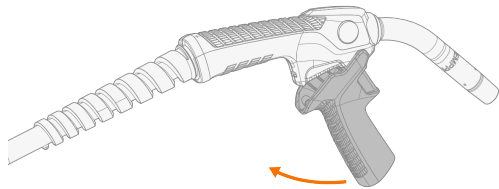

To remove the grip handle, press the unlock button in the grip handle rear:

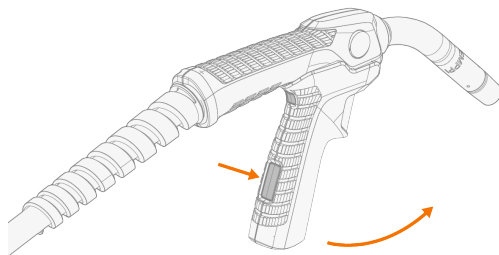

## 2.8 INSTALLING GAS BOTTLE AND TESTING GAS FLOW

**⚠** Handle gas bottles with care. There is a risk of injury if the gas bottle or the bottle valve is damaged!

**⚠** Always secure the gas bottle properly in an upright position to a special holder on the wall or on the welding equipment cart. Always keep the gas bottle valve closed when not welding.



- If a cart with a gas bottle rack is used, install the gas bottle on the cart first, then make the connections.

- The maximum recommended size of the gas bottle to be installed on the T22M cart is 20 liters.

- Minarc M 223P: Install the welding torch to the welding device before installing and testing the gas bottle.

Contact your local Kemppi dealer for choosing the gas and the equipment.

1. Without gas bottle cart: Place the gas bottle in a suitable, secure location.
2. With TM22 cart: Move the gas bottle on the transport unit's gas bottle rack and secure it in place with the straps and fixing points provided.

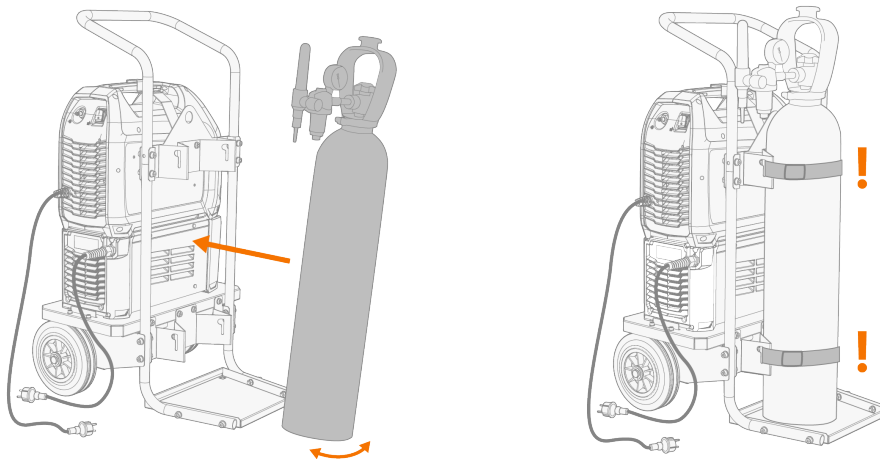

3. With MST400 cart: Move the gas bottle on the transport unit's gas bottle rack.

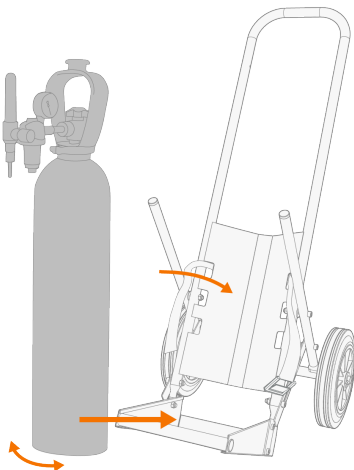

4. Secure the gas bottle in place with the strap provided.

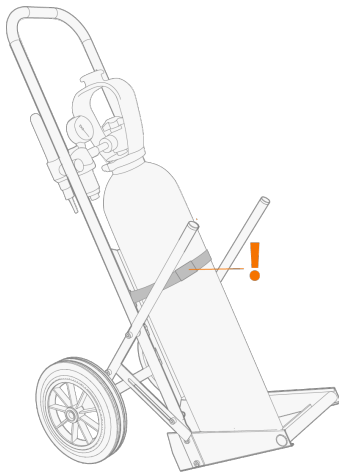

5. If not already, connect the welding torch to the welding device (refer to "Connecting welding torch (Flexlite GXe 223G3)" on page 29).
6. Connect the gas hose to the welding device.

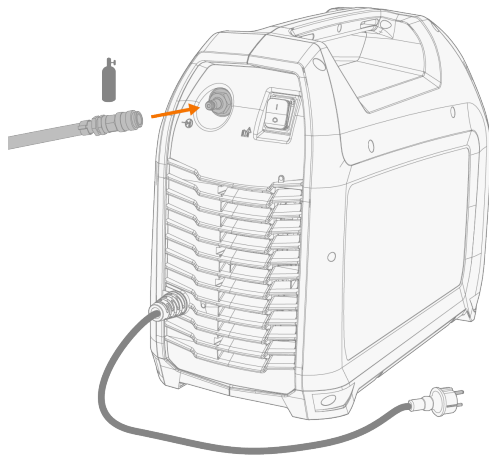

7. Open the gas bottle valve.
8. If the filler wire is installed, release the pressure handle and the fixed pressure roll of the wire feed mechanism to prevent wire feeding.

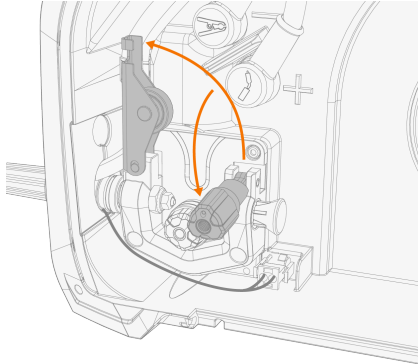

9. Start gas flow by pressing the gas test button or the welding torch trigger.
10. Check and adjust the gas flow. Use an external flow meter and regulator for measuring and adjustment.

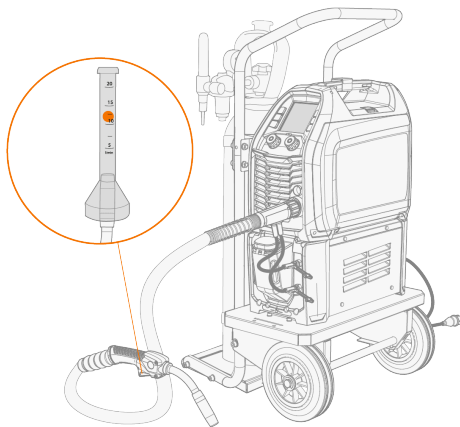

Recommended gas flow rates (for general guidance only):

	MIG*
Argon	10...25 l/min
Helium	-
Argon + 18-25% CO2	10...25 l/min
CO2	10...25 l/min

\* Depending on the gas nozzle size and welding current.

## 2.9 INSTALLING EQUIPMENT ON CART (OPTIONAL)

There are two transport unit options: T22M for installation with a cooling unit and MST400 for installation without a cooling unit.

 *The maximum recommended size of the gas bottle to be installed on the T22M cart is 20 liters.*

Tools needed:



**To install the Minarc M device and cooling unit on the T22M cart:**

1. Install the cooling unit on the cart.

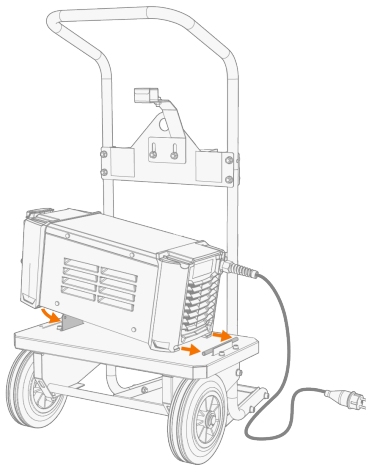

2. Fix the cooling unit to the cart with two screws (M5x12) in the front.
3. Place the Minarc M device on top of the cooling unit.

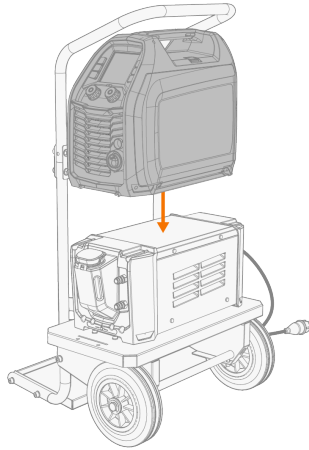

4. Secure the transportation handle to the cart with an additional bracket and a screw (M8x16).

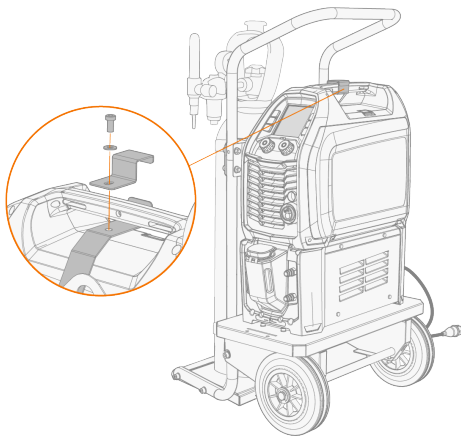

**To install the Minarc M device on the MST400 cart:**

1. Install the mounting bracket on the cart (for instructions on installing the gas bottle, refer to "Installing gas bottle and testing gas flow" on page 31).

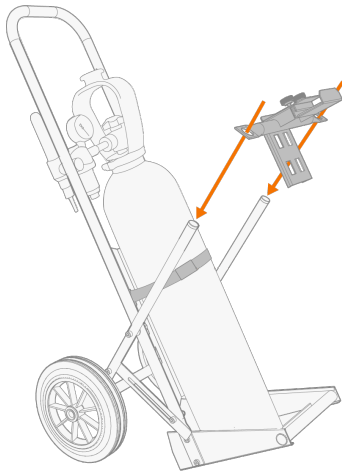

2. Mount the Minarc M device on the bracket. Slide the bracket so that it tightens onto the handle of the Minarc M device. Secure with the two fixing screws.

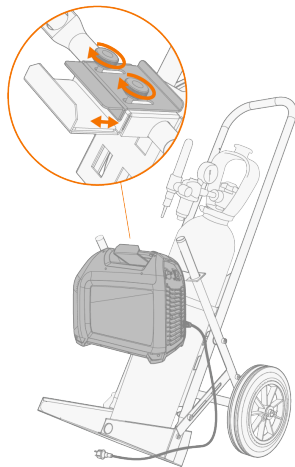

*Do not lift the equipment when it is installed on a cart. For more information, refer to "Lifting Minarc M equipment" on page 56.*

## 2.10 ATTACHING CARRYING STRAP (OPTIONAL)

The carrying strap is designed for manually moving the welding device in the workplace.



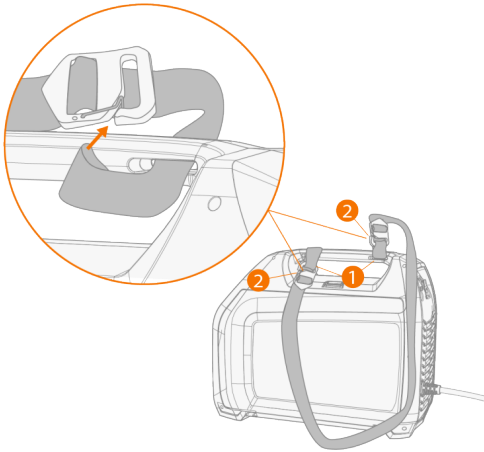

 *Always turn off the welding device before carrying it by the carrying strap.*

1. Thread the ends of the carrying strap through the slots in the lifting handle of the power source.
2. Attach the ends of the strap to the buckles with the spring locking mechanism.



### 3. OPERATION

Before using the equipment, ensure that all the necessary installation actions have been completed according to your equipment setup and instructions.

-  *Welding is forbidden in places where there is an immediate fire or explosion hazard!*
-  *The wire feed cabinet hatch must be kept closed when welding.*
-  *Check that there is enough space for cooling air circulation in the machine vicinity.*
-  *If the welding equipment is left unused for a longer period, disconnect the mains plug from the mains.*
-  *Always check before use that shielding gas hose, earth return cable and clamp and mains cable are in serviceable condition. Ensure that the connectors are correctly fastened. Loose connectors can impair welding performance and damage connectors.*

## 3.1 PREPARING WELDING DEVICE FOR USE

Before starting the use of the welding device:

- Ensure the installation has been completed
- Switch the welding device on

### Turning on welding device

To turn on the welding device, switch the main switch to ON (I).

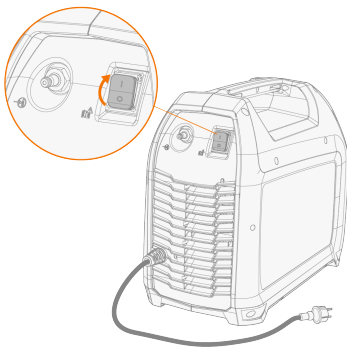

Use the main switch to start and shut down the welding device. Do not use the mains plug as a switch.

-  *If the machine is left unused for a longer period, detach the mains plug to disconnect it from the mains.*

### Connecting earth return cable

-  *Keep the work piece connected to earth to reduce the risk of injury to users or damage to electrical equipment.*

Attach the earth return cable clamp on the work piece.

Ensure that the contact surface is clean of metal oxide and paint and that the clamp is firmly secured.

## 3.2 MINARC M CONTROL PANEL

This section introduces the controls and features of the Minarc M control panel.

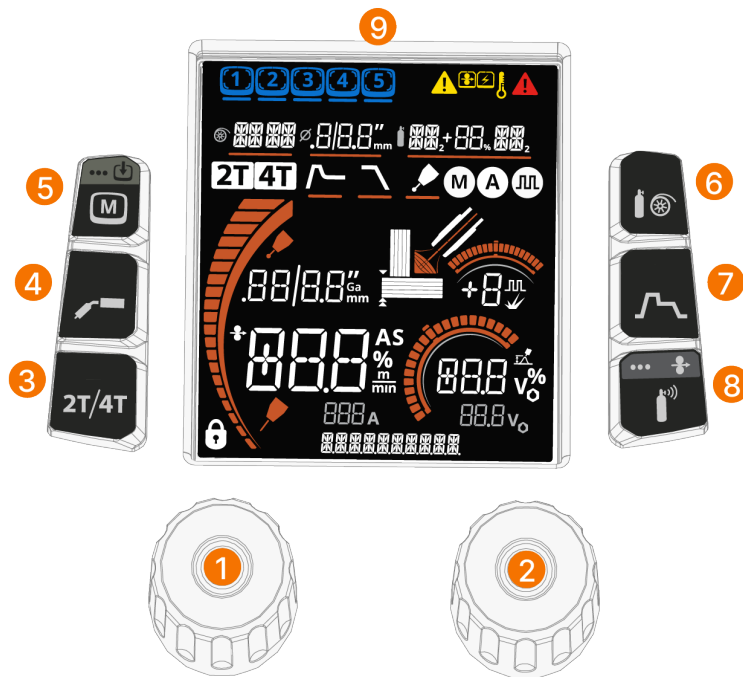

1. Left control knob (*more information below*)
    - >> Turn and press the control knob to make selections
  2. Right control knob (*more information below*)
    - >> Turn and press the control knob to make selections
  3. Trigger logic button
    - >> Trigger logic selection (2T/4T)
  4. Process and mode button
    - >> MIG welding process selection (Manual MIG (M) / 1-MIG (A) / Pulse MIG (⏏)). Use the right control knob to make the selection. When in Manual MIG mode, the short press of the button opens the material selection menu first.
- i** The Pulse MIG process is available only with Minarc M 223P with 220...240 V supply voltage.
5. Memory channel button
    - >> Short press: Change memory channel
    - >> Long press: Save to memory channel (refer to "Memory channels" on page 49)
  6. Material selection button
    - >> Filler wire material, thickness and shielding gas selection (refer to "Base settings for 1-MIG and Pulse MIG" on page 43)
  7. Welding parameters button
    - >> Additional welding parameters: Hot start / Crater fill / Post current / Voltage display (refer to "Additional welding parameters" on page 46)
  8. Gas test and wire inch button
    - >> Short press: Gas test, test the shielding gas flow and flush the gas line
    - >> Press and hold: Wire inch, drive the filler wire forward

 During gas test, the gas test time can be adjusted with the right control knob.

### 9. Control panel display.

>> For more information, refer to "Control panel display items" below

#### Control knob functions in main welding view

Left control knob:

- Manual MIG: Wire feed speed adjustment
- 1-MIG: Wire feed speed adjustment
- Pulse MIG: Wire feed speed adjustment.

Right control knob:

- Manual MIG: Welding voltage / Dynamics adjustment
- 1-MIG: Fine tuning of welding voltage / Dynamics (press to switch between adjusted parameters)
- Pulse MIG: Fine tuning / Pulse current (press to switch between adjusted parameters).

 The right control knob is the default control knob for adjustments and selections when saving welding parameters to a memory channel or when adjusting additional parameters.

 In most of the adjustment and setup views, pressing the left control knob or one of the side buttons returns back to the main view.

>> For more information, refer to "Main welding parameters" on page 44

**Safety lock:** By long-pressing the control knobs 1 and 2 simultaneously for 2 seconds, the device can be locked for safety. This prevents welding and operating the device by accident without having to turn the equipment off. Unlock the device by pressing the control knobs 1 and 2 simultaneously for 2 seconds.

**Factory reset:** By long-pressing the function buttons 3 and 8 (trigger logic and gas test buttons) simultaneously for 5 seconds, the device can be reset to factory settings.

 Resetting to factory settings will erase all user data.

## 3.2.1 CONTROL PANEL DISPLAY ITEMS



### 1. Memory channels (1..5)

>> Refer to "Memory channels" on page 49 for more information.



### 2. Warning and caution indicators

>> Refer to "Warning and error indicators" on page 50 for more information.





### 3. Filler wire material, diameter and shielding gas settings



4. Trigger logic, Hot start, Crater fill and Post current



5. MIG welding process indicators

	Manual MIG
	Automatic MIG (1-MIG)
	Pulse MIG



6. Safety lock indicator

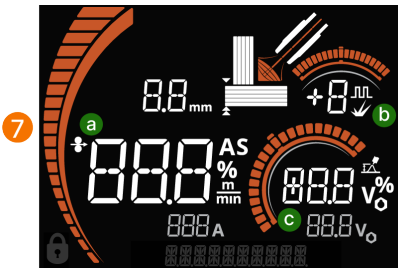

7. Main welding parameters:

a: Wire feed speed adjustment and indicator for material thickness

b: Dynamics or pulse adjustment

c: Voltage or voltage fine tuning



8. Arc / Terminal voltage indicators (arc voltage on the left, terminal voltage on the right). For information on selecting whether arc or terminal voltage is displayed during and briefly after welding, refer to "Additional welding parameters" on page 46



9. Information display

The information display shows the following parameters and settings as text:

- Version number display (activated by pressing any button during start-up)
- "FAILED": When an error occurs while saving a memory channel
- "FACT. RESET": Factory reset
- "LOCKED": When the safety lock is enabled (in addition to the lock icon)
- "HOT START": When adjusting Hot start (in addition to the Hot start icon)
- "CRATER FILL": When adjusting Crater fill (in addition to the Crater fill icon)
- "POST CURR.": When adjusting Post current (in addition to the Post current icon)
- "VOLT. ARC / VOLT. TERM": When selecting whether arc voltage ("VOLT. ARC") or terminal voltage ("VOLT. TERM") is shown during and briefly after welding
- "110-120 V NO PULSE": Appears for one minute when attempting to use a pulse memory channel with 110...120 V supply voltage
- The length of the filler wire driven with the wire inch button

Refer to "Main welding parameters" on the next page for more information on the welding parameters with each welding process.

You can also find the control panel symbols explained in "Minarc M control panel symbols and icons summary" on page 81.

### 3.2.2 BASE SETTINGS FOR 1-MIG AND PULSE MIG

For automatic 1-MIG (A) and Pulse MIG (JLL) welding, you are required to enter the filler wire and shielding gas information to determine the base welding program.

 *The Pulse MIG process is available only with Minarc M 223P with 220...240 V supply voltage.*

Manual MIG welding doesn't require the filler wire and shielding gas information to be specified.

The filler wire and shielding gas setup can be entered at any time by pressing the material selection button in the control panel.

1. Select filler wire material by turning and pressing the right control knob.



>> When the control knob is pressed to confirm the set value, the next settings value is automatically selected for adjustment. The value under adjustment is underlined.

2. Set filler wire diameter by turning and pressing the right control knob.

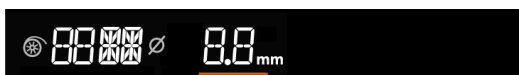

3. Select shielding gas by turning and pressing the right control knob.

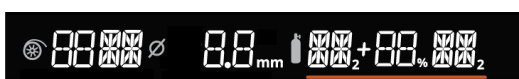

- Once the filler wire and shielding gas information has been entered, select the welding process by turning and pressing the right control knob. 1-MIG or Pulse MIG:



- While most of the available filler wire and shielding gas combinations are supported by both, 1-MIG and Pulse MIG process, some restrictions apply. For more information, refer to "Minarc M welding program work packs" on page 77.*

- Select a suitable memory channel to save the settings by turning and pressing the right control knob. On subsequent start-ups, the Minarc M starts with the last used welding process and memory channel.

### 3.2.3 MAIN WELDING PARAMETERS

The Minarc M control panel's main view displays the main welding parameters. The parameters shown and available for adjustment depend on the selected process.

The parameters' adjustments are accessed using the two control knobs below the display.

- The Pulse MIG process is available only with Minarc M 223P with 220...240 V supply voltage.*

#### Wire feed speed

MIG (M) 1-MIG (A) Pulse MIG

To adjust wire feed speed, turn the left control knob. The set wire feed speed (m/min) is shown on the screen. With 1-MIG and Pulse MIG processes, the estimated welding current (A) corresponding to the wire feed speed is displayed below the speed.



- Adjustment range: 0.5...18.0 m/min (or according to the welding program)
- Default setting: 5.0 m/min
- Adjustment steps: 0.1 m/min

#### Material thickness indicator

1-MIG (A) Pulse MIG

The material thickness value and indicator are shown based on the set wire feed speed with 1-MIG and Pulse MIG processes.



### Voltage fine tuning

1-MIG (A) Pulse MIG

With 1-MIG and Pulse MIG processes, the welding voltage can be fine-tuned by turning the right control knob. Especially with Pulse MIG, the adjustment essentially affects the arc length. The actual welding voltage is shown below the fine tuning value.



- Adjustment range: According to the welding program
- Default setting: 0.0 V
- Adjustment steps: 0.1 V

### Voltage

MIG (M)

With the manual MIG process, the welding voltage can be adjusted by turning the right control knob.



- Default setting: 14.0 V
- Adjustment steps: 0.1 V

### Pulse current

Pulse MIG

With the Pulse MIG process, the pulse current (peak) can be adjusted by first pressing (to switch to the pulse adjustment mode) and then turning the right control knob.



 The pulse current is adjusted as +/- percentage in relation to the initial pulse current defined in the welding program.

### Dynamics

MIG (M) 1-MIG (A)

With the manual MIG and 1-MIG processes, the dynamics can be adjusted by first pressing (to switch to the dynamics adjustment mode) and then turning the right control knob.



For more information on the available welding features and processes, refer to "Additional welding parameters" below and "Additional guidance to functions and features" on page 52.

## 3.2.4 ADDITIONAL WELDING PARAMETERS

To access the additional welding parameters, press the welding parameters button on the right side of the control panel display. The additional parameters include Hot start, Crater fill, and Post current (memory channel-specific start and stop parameters), and voltage display selection (arc voltage / terminal voltage).

The parameters available for adjustment depend on the selected process.

 The Pulse MIG process is available only with Minarc M 223P with 220...240 V supply voltage.

### Hot start

1-MIG (A) Pulse MIG

Hot start is a welding function that uses higher or lower wire feed speed and welding current at the start of the weld. After the Hot start period the current changes to normal welding current level. This facilitates the start of the weld especially with aluminum materials.

To adjust Hot start:

1. Press the welding parameters button to enter the welding parameters menu.
2. Turn the right control knob until the Hot start icon is underlined.



3. Select Hot start for adjustment by pressing the right control knob.
4. Turn the right control knob to turn Hot start ON or OFF and press the control knob button to select.
5. If Hot start is on: Adjust the Hot start time (s) by turning the right control knob. Confirm the set value by pressing the right control knob.
6. If Hot start is on: Once the Hot start time is set, adjust the Hot start level (%) by turning the right control knob. Confirm the set value by pressing the right control knob.

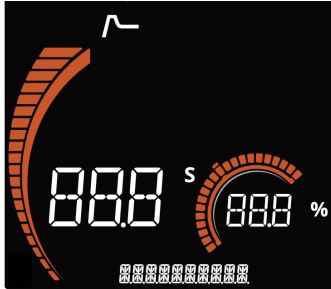

Hot start time:

- Adjustment range: 0.1...10.0 s
- Default setting: 1.2 s
- Adjustment steps: 0.1 s

 *Hot start time setting is not available with 4T trigger logic. Refer to "Trigger logic functions" on page 52 for more information.*

Hot start level:

- Adjustment range: 50...200 %
- Default setting: 140%
- Adjustment steps: 1%

### Crater fill

1-MIG (A) Pulse MIG

*When welding with high power, a crater is usually formed at the end of the weld. The Crater fill function decreases the welding power / wire feed speed at the end of the welding job so that the crater can be filled using a lower power level.*

To adjust Crater fill:

1. Press the welding parameters button to enter the welding parameters menu.
2. Turn the right control knob until the Crater fill icon is underlined.



3. Select Crater fill for adjustment by pressing the right control knob.
4. Turn the right control knob to turn Crater fill ON or OFF and press the control knob button to select.
5. If Crater fill is on: Adjust the Crater fill time (s) by turning the right control knob. Confirm the set value by pressing the right control knob.
6. If Crater fill is on: Once the Crater fill time is set, adjust the Crater fill end level (%) by turning the right control knob. Confirm the set value by pressing the right control knob.

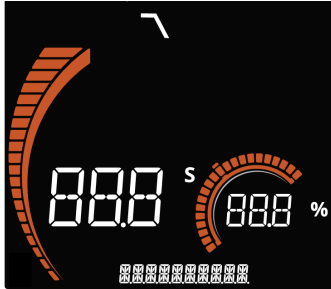

Crater fill time:

- Adjustment range: 0.1...10.0 s
- Default setting: 1.0 s
- Adjustment steps: 0.1 s

Crater fill end level:

- Adjustment range: 10...150 %
- Default setting: 30%
- Adjustment steps: 1%

### Post current

MIG (M) 1-MIG (A) Pulse MIG

Post current setting affects the wire length at the weld end, for example to prevent the wire from stopping too close to the weld pool. This also enables the optimum wire length for the start of the next weld.

To adjust Post current:

1. Press the welding parameters button to enter the welding parameters menu.
2. Turn the right control knob until the Post current icon is underlined.



3. Select Post current for adjustment by pressing the right control knob.
4. Adjust Post current by turning the right control knob. Confirm the set value by pressing the right control knob.

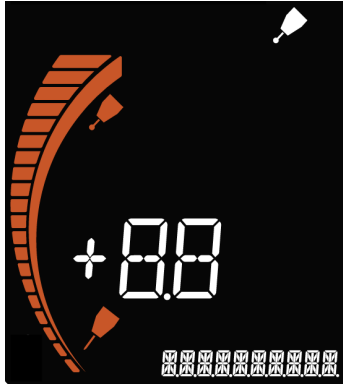

- Adjustment range: -30...+30
- Default setting: 0
- Adjustment steps: 1

#### Voltage display

MIG (M) 1-MIG (A) Pulse MIG

You can choose whether the arc voltage or terminal voltage is shown during and briefly after welding.

1. Press the welding parameters button to enter the welding parameters menu.
2. Turn the right control knob until the text "VOLT. ARC / VOLT. TERM" is displayed at the bottom of the display (for more information, refer to "Control panel display items" on page 41).
3. Select the arc voltage ("VOLT. ARC") or terminal voltage ("VOLT. TERM") by pressing the right control knob.

### 3.2.5 MEMORY CHANNELS

To change the memory channel, press the memory channel button on the control panel. This selects the next available memory channel.

The top of the Minarc M control panel display indicates which of the five available memory channels is currently selected:



If the welding parameters have been changed from the ones saved on the memory channel (i.e. a work channel has been created), this is indicated with a dotted line in the channel selection:



To save the adjusted welding parameters to a memory channel, follow these steps:

1. Long-press the memory channel button in the control panel to enter the memory channel saving mode.



- Turn the right control knob to change the memory channel (where to save).



- Press the right control knob to select the memory channel (where to save).

>> Once saved, the newly saved memory channel is automatically selected.







On start-up, Minarc M starts with the last used memory channel.

 A new 1-MIG or Pulse MIG memory channel can be created using the material selection wizard. For more information, refer to "Base settings for 1-MIG and Pulse MIG" on page 43.

### 3.2.6 WARNING AND ERROR INDICATORS

These warning and error indicators are located in the top-right corner of the Minarc M control panel display.

Indicator symbol definitions:

	Warning: This symbol indicates an error or fault that requires attention, but doesn't prevent welding
	Error: This symbol indicates an error or fault that prevents welding and requires immediate action
	Error or fault with power source
	Error or fault with wire feeder
	Overheating error
	Error (error code is shown together with this text)

 *If the power source overheats, a thermal cutoff switches the unit off and does not allow it to be used until it has cooled down.*

For error codes, refer to "Error codes" on page 58.

### 3.2.7 WELDING VIEW

During welding, the control panel display shows the welding current and, depending on your choice, either the arc voltage or the terminal voltage.

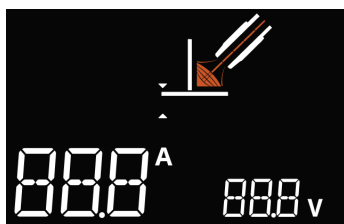

Adjusting the main welding parameters is also possible during welding by turning the control knobs. Depending on the welding process used, and if applicable, pressing the right control knob switches between the secondary welding parameters (e.g. fine tuning and dynamics).

- >> When starting to adjust the welding parameters during welding, the view is temporarily changed from the welding view to the main view to show the adjusted welding parameters for the current welding process (e.g. wire feed speed and fine tuning).

### 3.2.8 WELD DATA

After each weld, a weld summary (weld data) is displayed briefly.



The current and voltage values shown in the weld data view are average values of the weld.

### 3.2.9 WIRE INCH

With Minarc M, the wire inch function is operated with the control panel button. Refer to "Minarc M control panel" on page 40 for more information on the control panel operation.

The wire feed speed is displayed during wire inch. It can be adjusted during wire inch by turning the left control knob.

### 3.2.10 GAS TEST

With Minarc M, the gas test function is operated with the control panel button. Refer to "Minarc M control panel" on page 40 for more information on the control panel operation.

The gas test time is displayed during gas test. It can be adjusted during gas test by turning the left control knob.

## 3.3 ADDITIONAL GUIDANCE TO FUNCTIONS AND FEATURES

This section further describes some of the Minarc M functions and features and how to use them.

### 3.3.1 1-MIG



The automatic 1-MIG (A) is a synergic MIG/MAG welding process where the welding voltage is defined automatically when you adjust the wire feed speed. The voltage is calculated based on the welding program in use. The process is suitable for all materials, shielding gases and welding positions.

>> To take 1-MIG (A) into use, select an existing memory channel with 1-MIG process.

If there aren't any 1-MIG (A) memory channels available, create a new one for 1-MIG process by defining the filler wire and shielding gas information and selecting 1-MIG (A) as the welding process. Refer to "Base settings for 1-MIG and Pulse MIG" on page 43 for more information on defining the base settings and process.

>> Once selected, the corresponding 1-MIG (A) welding process parameters become available for adjustment in the main view.

### 3.3.2 PULSE



 *The Pulse MIG process is available only with Minarc M 223P with 220...240 V supply voltage.*

Pulse is a synergic MIG/MAG welding process where the current is pulsed between the base current and the pulse current.

The advantages of pulse welding are a higher welding speed and deposition rate compared to short-arc welding, lower heat input compared to spray-arc welding, a spatter-free globular arc and smooth appearance of the weld. Pulse is suitable for all position welding. It is excellent for welding aluminum and stainless steel, especially when the material thickness is small.

>> To take Pulse welding process into use, select an available Pulse channel.

If there aren't any Pulse memory channels available, create a new one for Pulse process by defining the filler wire and shielding gas information and selecting Pulse as the welding process. Refer to "Base settings for 1-MIG and Pulse MIG" on page 43 for more information on defining the base settings and process.

>> Once selected, the corresponding Pulse welding process parameters become available for adjustment in the main view.

### 3.3.3 TRIGGER LOGIC FUNCTIONS

You can select the trigger logic by pressing the trigger logic selection button in the control panel ("Minarc M control panel" on page 40).

#### 2T

In 2T, pressing the trigger ignites the arc. Releasing the trigger switches the arc off.



#### 4T

In 4T, pressing the trigger starts the pre gas, and releasing the trigger ignites the arc. Pressing the trigger again switches the arc off. Releasing the trigger ends the post gas.



If Hot start is used with 4T, pressing the trigger starts the pre gas for a predefined duration, after which the arc ignites automatically and the current raises to the Hot start level. The current is lowered to the normal welding current level once the trigger is released. If the trigger is released before the start sequence reaches the Hot start phase, the arc is ignited without Hot start.

## 3.4 CHANGING WELDING POLARITY

Some filler wires require changing the welding polarity. Check the recommended welding polarity on the filler wire package.

 *Before handling electrical parts, ensure the welding device is disconnected from the mains.*

Tools needed:



T30

1. Turn off the welding device and disconnect it from the mains.
2. Open the wire feed cabinet hatch.
3. Remove the protective rubber covers from the polarity terminals.

 *Use caution when handling electrical parts.*

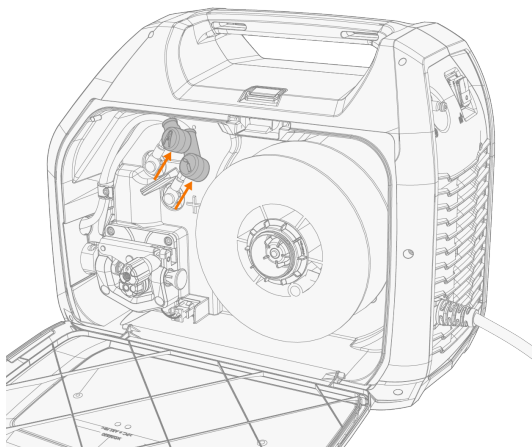

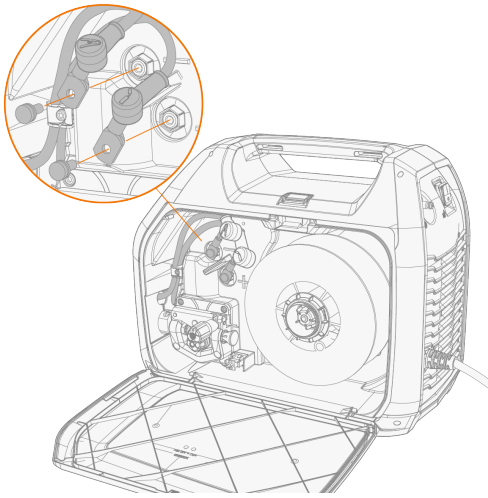

4. Remove the terminal tightening bolts.



5. Connect the cables to the polarity terminals according to the polarity recommendation.
6. Replace the bolts. Tighten to 5 Nm torque.
7. Replace the protective rubber covers.

### 3.5 LIFTING MINARC M EQUIPMENT

 Do not attempt to lift the device with a hoist when the device is installed on a cart.

 Do not attempt to lift the device with a hoist from the carrying strap.

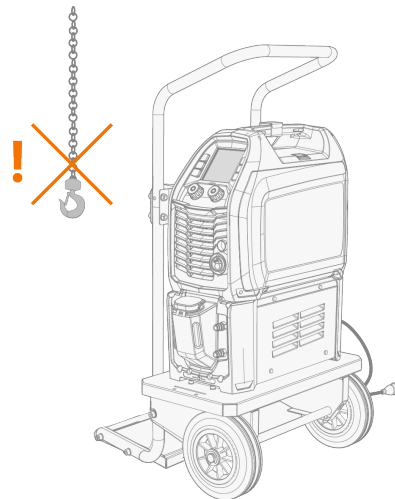
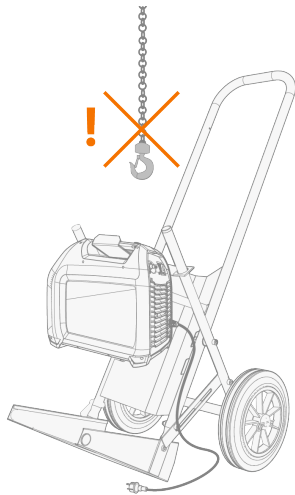

#### Handle:

The handle can be used for mechanical lifting (for moving only, not for hanging) when the device is not mounted on a cart.

Connect the hoist hook to the handle.

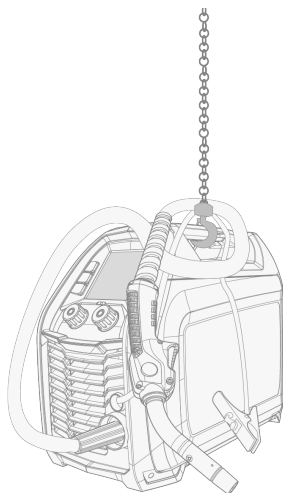

## 3.6 TROUBLESHOOTING

**i** *The problems listed and the possible causes are not definitive, but suggest some typical situations that may turn up during normal use of the welding system.*

*Welding device:*

Problem	Recommended actions
The welding device does not power up	Check that the mains cable is plugged in properly.
	Check that the mains switch of the power source is at the ON position.
	Check that the mains power distribution is on.
	Check the mains fuse and/or the circuit breaker.
	Check that the earth return cable is connected.
The welding device stops working	Gas-cooled gun may have overheated. Wait for it to cool down.
	Check that none of the cables is loose.
	The wire feeder may have overheated. Wait for it to cool down and see that the welding current cable is properly attached.
	The power source may have overheated. Wait for it to cool down and see that the cooling fans work properly and the air flow is unobstructed.

*Wire feeding:*

Problem	Recommended actions
The filler wire on the spool unravels	Check that the spool locking cover is closed.
The wire feed mechanism does not feed the filler wire	Check that the filler wire has not run out.
	Check that the filler wire is properly routed through the feed rolls to the wire liner.
	Check that the pressure handle is properly closed.
	Check that the feed roll pressure is adjusted correctly for the filler wire.
	Check that the welding cable is properly connected to the wire feeder.
	Blow compressed air through the wire liner to check that it is not blocked.

*Weld quality:*

Problem	Recommended actions
Dirty and/or poor quality weld	Check that the shielding gas has not run out.
	Check that the shielding gas flow is unobstructed.
	Check that the gas type is correct for the application.
	Check the polarity of the gun/electrode.
Varying welding performance	Check that the welding procedure is correct for the application.
	Check that the wire feed mechanism is adjusted properly.
	Blow compressed air through the wire liner to check that it is not blocked.
	Check that the wire liner is correct for the selected wire size and type.
	Check the welding gun contact tip's size, type and wear.
	Check that the welding gun is not overheating.
High spatter volume	Check that the earth return clamp is properly attached to a clean surface of the workpiece.
	Check the welding parameter values and welding procedure.
	Check the gas type and flow.
	Check the polarity of the gun/electrode.
	Check that the filler wire is correct for the current application.

"Error codes" below

### 3.6.1 ERROR CODES

In error situations, the control panel displays the number, title and possible cause of the error, and a proposed action to fix the issue.

Error			
Code	Title	Possible cause	Proposed action
1	Power source not calibrated	Power source calibration has been lost.	Restart the power source. If problem persists, contact Kemppi service.
2	Too low mains voltage	Voltage in mains network is too low.	Restart the power source. If problem persists, contact Kemppi service.
3	Too high mains voltage	Voltage in mains network is too high.	Restart the power source. If problem persists, contact Kemppi service.
4	Power source is overheated	Too long welding session with high power.	Do not shut down, let the fans cool the machine. If fans are not running, contact Kemppi service

5	Internal 24V voltage is too low	Power source contains an inoperative 24V power supply unit .	Restart the power source. If problem persists, contact Kemppi service.
12	Welding cable failure	Plus and minus cables are connected together.	Check the connections of welding cable and earth return cable.
14	IGBT overheated	Too long welding session with high power or high ambient temperature.	Do not shut down, let the fans cool the machine. If fans are not running, contact Kemppi service.
43	Overcurrent in wire feeder motor	There may be too much pressure in the wire feed rolls or dirt in the wire line.	Adjust the feed roll pressure. Clean the wire line. Change worn parts in the welding gun.
81	Welding program data missing	Welding program data has been lost.	Restart the power source. If problem persists, contact Kemppi service.

## 4. MAINTENANCE

## 4.1 ASSEMBLING WELDING TORCH (FLEXLITE GXE 223GMM3)

Welding torches come pre-assembled. Refer to this section when the Flexlite GXe 223GMM3 welding torch needs to be reassembled (e.g., after maintenance).

Tools needed:

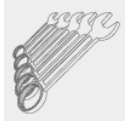

7, 12 mm

1. Attach the insulating ring.
2. Attach the contact tip adapter and tighten to 3 Nm torque.
3. Attach the contact tip and tighten to 3 Nm torque.
4. Attach the gas nozzle and hand-tighten it firmly in place.

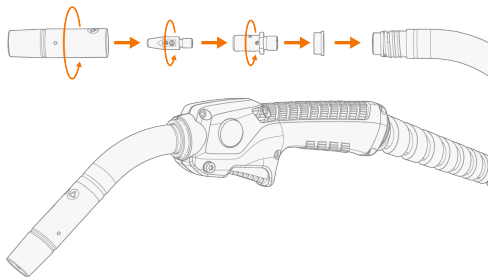

## 4.2 CHANGING WELDING TORCH (FLEXLITE GXE 223GMM3)

This section describes how to change the fixed welding torch Flexlite GXe 223GMM3.

 Use caution when handling electrical parts.

 The filler wire must be removed before changing the welding torch.

Tools needed:

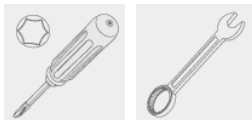

T20, T30

17 mm

1. Turn off the welding device.
2. Release the pressure handle and fixed pressure roll.

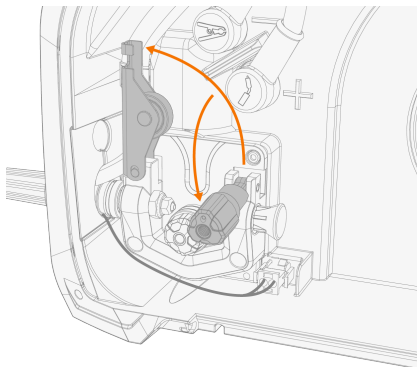

3. Remove the wire spool and wire from the wire feeder and welding torch (refer to "Installing and changing wire and spool (200 mm)" on page 16).
4. Detach the welding torch trigger cable.

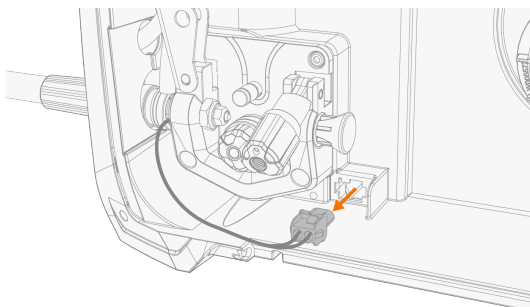

5. Release the welding current cable: Loosen the cable retaining clamp and detach the welding current cable from the polarity terminal.

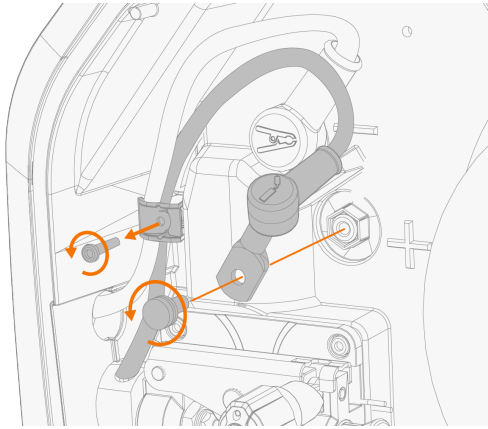

6. Remove the welding torch retaining nut.

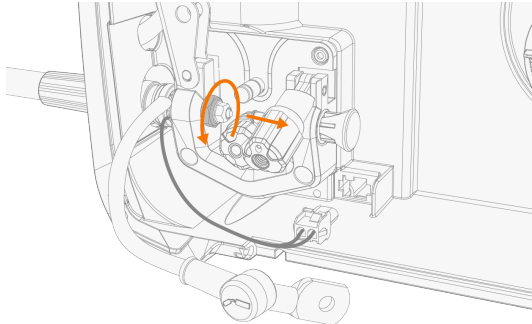

7. Remove the welding torch by pulling it out.

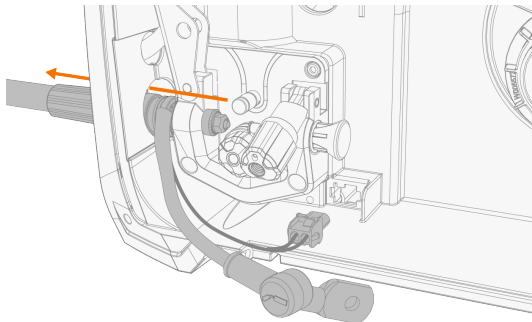

8. Follow the previous steps in reverse to install the new welding torch.

 **Make sure that there is enough clearance between the welding current cable and the wire feed mechanism to prevent damage to the cable when releasing the pressure handle and the fixed pressure roll.**





 **Make sure that the O-ring installed in the welding torch retaining nut is not damaged. If necessary, use water as a lubricant when installing the welding torch.**

## 4.3 DAILY, PERIODIC AND ANNUAL MAINTENANCE

When considering and planning routine maintenance, consider the operating frequency of the welding system and the working environment.

Correct operation of the welding machine, regular maintenance, and the use of original Kemppi spare parts and consumables help you avoid unnecessary downtime and equipment failure, while also maximizing the equipment's service life.

For repairs, find your closest Kemppi service workshop at [www.kemppi.com](http://www.kemppi.com) or contact your dealer.

-  *Only an authorized electrician is allowed to carry out electrical work.*
-  *Only qualified service personnel is allowed to carry out periodic and annual maintenance.*
-  *Disconnect the power source from the mains before handling electrical cables and connectors.*
-  *Do not use pressure washing devices.*
-  *Where applicable, use the correct tension torque when fastening loose parts.*

### Daily maintenance

Welding equipment's daily maintenance:

- Check that all covers and components are intact.
- Check all the cables, hoses and connectors. Do not use them if they are damaged.
- Ensure that the connectors are correctly fastened. Loose connectors can impair welding performance and damage connectors.
- Check the wire feeder's feed rolls and the pressure handle mechanism. Clean and lubricate with a small quantity of light machine oil if needed.

Welding torch's daily maintenance:

- Check regularly that all the components are tightly fastened.
- Check that the current transfer surface on the Kemppi torch adapter is clean and unscratched, and the connector pins are straight and undamaged.
- Check the protective hose on the cable for damage.
- Check the O-rings in the welding torch gas connector for wear and damage.
- Clean dust from the liner with pressurized air every time you change the wire spool, or every day during heavy use.
- Check and remove any spatter build-up from the nozzle.

### Weekly maintenance

Welding equipment's weekly maintenance:

- Clean the outside parts of the units from dust and dirt, for example, with a soft brush and vacuum cleaner.
- Clean the ventilation grills. Do not use compressed air, there is a risk that the dirt will compact even more tightly into the gaps of the cooling profiles.

### Periodic maintenance

Welding equipment's periodic maintenance, every 1–6 months:

- Check the electrical connectors of the equipment at least every 6 months. Clean oxidized parts and tighten loose connectors.
- Update the welding system to the latest firmware and software versions, as applicable.

### Annual maintenance

The annual maintenance must be carried out by an authorized Kemppi service workshop. Kemppi service workshops complete the welding system maintenance according to your Kemppi service agreement. Find your closest service workshop at [www.kemppi.com](http://www.kemppi.com).

Welding equipment's annual maintenance program includes:

- Cleaning the equipment.
- Maintenance of the welding tools.
- Checking the connectors and switches.
- Checking all electrical connections.
- Checking the power source mains cable and plug.
- Repairing defective parts and replacing defective components.
- Maintenance test.
- Testing the operation and calibrating the performance values when needed.
- Updating the welding system to the latest firmware and software versions, and installing new welding software.
- If a cooling unit is used: Checking and cleaning the cooling liquid pump. The pump is dismantled and cleaned thoroughly, and if there has been any leakage in the pump's axle seal point, the axle seal is replaced. The axle seal is subject to wear and may need replacement periodically to maintain proper sealing.

For Kemppi welding torch maintenance, refer to your welding torch's instructions (available also at [user-doc.kemppi.com](http://user-doc.kemppi.com)).

## 4.4 DISPOSAL



Do not dispose of any electrical equipment with normal waste!

In observance of WEEE Directive 2012/19/EU on waste of electrical and electronic equipment and European Directive 2011/65/EU on the restriction of the use of certain hazardous substances in electrical and electronic equipment, and their implementation in accordance with national law, electrical equipment that has reached the end of its life must be collected separately and taken to an appropriate environmentally responsible recycling facility. The owner of the equipment is obliged to deliver a decommissioned unit to a regional collection center, as per the instructions of local authorities or a Kempfi representative. By applying these European Directives you improve the environment and human health.

For more information:



## 5. TECHNICAL DATA

### Technical data:

- "Minarc M devices" on the next page
- "Flexlite GXe 223GMM3 welding torch" on page 74
- For the technical data of Flexlite GXe 223G3 welding torch, refer to [Kempfi Userdoc](#)

### Additional information:

- "Wire feeder consumables" on page 75
- "Minarc M welding program work packs" on page 77
- "Minarc M ordering info" on page 80
- "Minarc M control panel symbols and icons summary" on page 81

## 5.1 MINARC M DEVICES

### Minarc M 223 Auto GM

Minarc M 223 Auto GM		
Feature		Value
Mains connection voltage		220...240 V ±10 %
Mains connection voltage	MV low range	110...120 V ±10 %
Mains connection phases		1~50/60 Hz
Mains connection cable type		3G, H07RN-F
Mains connection cable size		2.5 mm <sup>2</sup>
Rated maximum input power [ $S_{1max}$ ]		7 kVA
Mains fuse		16 A
Mains fuse	@MV low range	15 A
Idle state power consumption [ $P_{idle}$ ]		10 W
No-load voltage [ $U_0$ ]		40 V
No-load voltage [ $U_0$ ]	@MV low range	40 V
Effective supply current [ $I_{1eff}$ ]		16 A
Effective supply current [ $I_{1eff}$ ]	@MV low range	15 A
Maximum supply current [ $I_{1max}$ ]		30 A
Maximum supply current [ $I_{1max}$ ]	@MV low range	28 A
Output, duty cycle % at rated max current, MIG		20 %
Output at +40 °C, rated max current, MIG		220 A
Output at +40 °C, 60% MIG		160 A
Output at +40 °C, 100% MIG		140 A
Output, duty cycle % at rated max current, MIG	@MV low range	20 %
Output at +40 °C, rated max current, MIG	@MV low range	120 A
Output at +40 °C, 60% MIG	@MV low range	95 A
Output at +40 °C, 100% MIG	@MV low range	75 A
Output range, MIG welding current/voltage		15 A / 11 V ... 220 A / 28 V
Output range, MIG welding current/voltage	@MV low range	15 A / 11 V ... 120 A / 23 V
Voltage adjustment range (MIG)		10...32 V
Power factor at rated maximum current	$\lambda$	1
Efficiency at rated maximum current	$\eta$	85 %
Welding connection type		Built-in
Wire feed mechanism		Single-motor, 2-roll
Diameter of feed rolls		30 mm
Filler wire diameter, Fe		0.6...1.2 mm
Filler wire diameter, Ss		0.6...1 mm

Filler wire diameter, Al		0.8...1.2 mm
Filler wire diameter, Fe-MC/FC		1...1.2 mm
Wire feed speed		0.5...18 m/min
Maximum wire spool weight		5 kg
Maximum wire spool diameter		200 mm
Operating temperature range		-20...40 °C
Storage temperature range		-40...60 °C
Recommended minimum generator power [ $S_{gen}$ ]		8 kVA
EMC class		A
Degree of protection		IP23
External dimensions	<i>L x W x H</i>	460 x 221 x 365 mm
Weight without accessories		12 kg
Standards		IEC 60974-1, -10

### Minarc M 223 Auto GM AU

Minarc M 223 Auto GM AU		
Feature		Value
Mains connection voltage		230...240 V ±10 %
Mains connection voltage	MV low range	110...120 V ±10 %
Mains connection phases		1~50/60 Hz
Mains connection cable type		3G, H07RN-F
Mains connection cable size		1.5 mm <sup>2</sup>
Rated maximum input power [ $S_{1max}$ ]		7 kVA
Mains fuse		15 A
Mains fuse	@MV low range	15 A
Idle state power consumption [ $P_{idle}$ ]		10 W
No-load voltage [ $U_0$ ]		40 V
No-load voltage [ $U_0$ ]	@MV low range	40 V
Effective supply current [ $I_{1eff}$ ]		15 A
Effective supply current [ $I_{1eff}$ ]	@MV low range	15 A
Maximum supply current [ $I_{1max}$ ]		29 A
Maximum supply current [ $I_{1max}$ ]	@MV low range	28 A
Output, duty cycle % at rated max current, MIG		20 %
Output at +40 °C, rated max current, MIG		220 A
Output at +40 °C, 60% MIG		160 A
Output at +40 °C, 100% MIG		140 A
Output, duty cycle % at rated max current, MIG	@MV low range	20 %
Output at +40 °C, rated max current, MIG	@MV low range	120 A

Output at +40 °C, 60% MIG	@MV low range	95 A
Output at +40 °C, 100% MIG	@MV low range	75 A
Output range, MIG welding current/voltage		15 A / 11 V ... 220 A / 28 V
Output range, MIG welding current/voltage	@MV low range	15 A / 11 V ... 120 A / 23 V
Voltage adjustment range (MIG)		10...32 V
Power factor at rated maximum current	$\lambda$	1
Efficiency at rated maximum current	$\eta$	85 %
Welding connection type		Built-in
Wire feed mechanism		Single-motor, 2-roll
Diameter of feed rolls		30 mm
Filler wire diameter, Fe		0.6...1.2 mm
Filler wire diameter, Ss		0.6...1 mm
Filler wire diameter, Al		0.8...1.2 mm
Filler wire diameter, Fe-MC/FC		1...1.2 mm
Wire feed speed		0.5...18 m/min
Maximum wire spool weight		5 kg
Maximum wire spool diameter		200 mm
Operating temperature range		-20...40 °C
Storage temperature range		-40...60 °C
Recommended minimum generator power [ $S_{gen}$ ]		8 kVA
EMC class		A
Degree of protection		IP23
External dimensions	$L \times W \times H$	460 x 221 x 365 mm
Weight without accessories		12 kg
Standards		IEC 60974-1, -10

### Minarc M 223P Auto GM

Minarc M 223P Auto GM		
Feature		Value
Mains connection voltage		220...240 V $\pm$ 10 %
Mains connection voltage	MV low range	110...120 V $\pm$ 10 %
Mains connection phases		1~50/60 Hz
Mains connection cable type		3G, H07RN-F
Mains connection cable size		2.5 mm <sup>2</sup>
Rated maximum input power [ $S_{1max}$ ]		7 kVA
Mains fuse		16 A
Mains fuse	@MV low range	15 A
Idle state power consumption [ $P_{1idle}$ ]		10 W

No-load voltage [ $U_0$ ]		40 V
No-load voltage [ $U_0$ ]	@MV low range	40 V
Effective supply current [ $I_{\text{eff}}$ ]		16 A
Effective supply current [ $I_{\text{eff}}$ ]	@MV low range	15 A
Maximum supply current [ $I_{\text{max}}$ ]		30 A
Maximum supply current [ $I_{\text{max}}$ ]	@MV low range	28 A
Output, duty cycle % at rated max current, MIG		20 %
Output at +40 °C, rated max current, MIG		220 A
Output at +40 °C, 60% MIG		160 A
Output at +40 °C, 100% MIG		140 A
Output, duty cycle % at rated max current, MIG	@MV low range	20 %
Output at +40 °C, rated max current, MIG	@MV low range	120 A
Output at +40 °C, 60% MIG	@MV low range	95 A
Output at +40 °C, 100% MIG	@MV low range	75 A
Output range, MIG welding current/voltage		15 A / 11 V ... 220 A / 28 V
Output range, MIG welding current/voltage	@MV low range	15 A / 11 V ... 120 A / 23 V
Voltage adjustment range (MIG)		10...32 V
Power factor at rated maximum current	$\lambda$	1
Efficiency at rated maximum current	$\eta$	0.85 %
Welding connection type		Euro
Wire feed mechanism		Single-motor, 2-roll
Diameter of feed rolls		30 mm
Filler wire diameter, Fe		0.6...1.2 mm
Filler wire diameter, Ss		0.6...1 mm
Filler wire diameter, Al		0.8...1.2 mm
Filler wire diameter, Fe-MC/FC		1...1.2 mm
Wire feed speed		0.5...18 m/min
Maximum wire spool weight		5 kg
Maximum wire spool diameter		200 mm
Operating temperature range		-20...40 °C
Storage temperature range		-40...60 °C
Recommended minimum generator power [ $S_{\text{gen}}$ ]		8 kVA
EMC class		A
Degree of protection		IP23
External dimensions	$L \times W \times H$	460 x 221 x 365 mm
Weight without accessories		10.85 kg
Standards		IEC 60974-1, -10

**Minarc M 223P Auto GM AU**

Minarc M 223P Auto GM AU		
Feature		Value
Mains connection voltage		230...240 V ±10 %
Mains connection voltage	MV low range	110...120 V ±10 %
Mains connection phases		1~50/60 Hz
Mains connection cable type		3G, H07RN-F
Mains connection cable size		1.5 mm <sup>2</sup>
Rated maximum input power [ $S_{1max}$ ]		7 kVA
Mains fuse		15 A
Mains fuse	@MV low range	15 A
Idle state power consumption [ $P_{idle}$ ]		10 W
No-load voltage [ $U_0$ ]		40 V
No-load voltage [ $U_0$ ]	@MV low range	40 V
Effective supply current [ $I_{1eff}$ ]		15 A
Effective supply current [ $I_{1eff}$ ]	@MV low range	15 A
Maximum supply current [ $I_{1max}$ ]		29 A
Maximum supply current [ $I_{1max}$ ]	@MV low range	28 A
Output, duty cycle % at rated max current, MIG		20 %
Output at +40 °C, rated max current, MIG		220 A
Output at +40 °C, 60% MIG		160 A
Output at +40 °C, 100% MIG		140 A
Output, duty cycle % at rated max current, MIG	@MV low range	20 %
Output at +40 °C, rated max current, MIG	@MV low range	120 A
Output at +40 °C, 60% MIG	@MV low range	95 A
Output at +40 °C, 100% MIG	@MV low range	75 A
Output range, MIG welding current/voltage		15 A / 11 V ... 220 A / 28 V
Output range, MIG welding current/voltage	@MV low range	15 A / 11 V ... 120 A / 23 V
Voltage adjustment range (MIG)		10...32 V
Power factor at rated maximum current	$\lambda$	1
Efficiency at rated maximum current	$\eta$	85 %
Welding connection type		Euro
Wire feed mechanism		Single-motor, 2-roll
Diameter of feed rolls		30 mm
Filler wire diameter, Fe		0.6...1.2 mm
Filler wire diameter, Ss		0.6...1 mm
Filler wire diameter, Al		0.8...1.2 mm
Filler wire diameter, Fe-MC/FC		1...1.2 mm
Wire feed speed		0.5...18 m/min

Maximum wire spool weight		5 kg
Maximum wire spool diameter		200 mm
Operating temperature range		-20...40 °C
Storage temperature range		-40...60 °C
Recommended minimum generator power [ $S_{gen}$ ]		8 kVA
EMC class		A
Degree of protection		IP23
External dimensions	<i>L x W x H</i>	460 x 221 x 365 mm
Weight without accessories		10.85 kg
Standards		IEC 60974-1, -10

## 5.2 FLEXLITE GXE 223GMM3 WELDING TORCH

GXe 223GMM3	
Feature	Value
Welding connection type	Built-in
Type of cooling	Air
Contact tip	M6
Method of guidance	Manual
Load capacity 35% / Ar + 18% CO2	220 A
Load capacity test, filler wire material	Fe
Load capacity test, filler wire diameter	1 mm
Load capacity test, stick out length	15 mm
Load capacity test, gas flow	13 l/min
Filler wire diameter	0.6...1 mm
Filler wire diameter, Fe	0.6...1 mm
Filler wire diameter, Ss	0.8...1 mm
Filler wire diameter, Al	0.8...1 mm
Filler wire diameter, Fe-MC/FC	0.9...1 mm
Filler wire diameter, Ss-MC/FC	0.9...1 mm
Gun handle	Yes
Neck type	Rotating
Neck dimensions: length	107 mm
Neck dimensions: height	65 mm
Neck dimensions: angle	40 °
Cable type	Coaxial
Remote control	No
LED light	No
Operating temperature range	-20...40 °C
Storage temperature range	-40...60 °C
Standards	IEC 60974-7

## 5.3 WIRE FEEDER CONSUMABLES

This section lists the feed rolls and wire guide tubes available both separately and in consumable kits. The consumable kits contain recommended feed roll and wire guide tube combinations for selected filler wire materials and diameters. The wire feeder consumables can be ordered in [Configurator.kemppi.com](https://configurator.kemppi.com).

The materials mentioned first refer to primary suitability and the materials mentioned inside brackets refer to secondary suitability.

"Minarc M 223 wire feeder consumables" below

"Minarc M 223P wire feeder consumables " on the next page

*Feed roll profiles and corresponding symbols:*

Feed roll profile	Symbol
V-groove	V
V-groove, knurled	V≡
U-groove	U

### 5.3.1 MINARC M 223 WIRE FEEDER CONSUMABLES

#### Wire feeder consumable kits

The table below lists the recommended consumable kits for selected filler wire materials and diameters.

Wire feeder consumable kits			
Filler wire material	Feed roll profile	Filler wire diameter (mm)	Consumable kit code
Fe (MC/FC)	V-groove	0.6 / 0.8–0.9	F000605
		1.0 / 1.2	F000606
Ss Cu (Fe)	V-groove	0.6 / 0.8–0.9	F000607
		1.0 / 1.2	F000608
MC/FC	V-groove, knurled	1.0 / 1.2	F000609

#### Wire guide tubes

The table below lists the wire guide tubes available.

Wire guide tubes		
Filler wire material	Filler wire diameter (mm)	Inlet guide tube
Fe (MC/FC)	0.8–0.9	SP007536
	1.2	SP007538
Ss, Cu (Fe)	0.8–0.9	SP007294
	1.2	SP007296
MC/FC	1.2	SP007538

### 5.3.2 MINARC M 223P WIRE FEEDER CONSUMABLES

#### Wire feeder consumable kits

The table below lists the recommended consumable kits for selected filler wire materials and diameters.

Wire feeder consumable kits			
Filler wire material	Feed roll profile*	Filler wire diameter (mm)	Consumable kit code
Fe (MC/FC)	V-groove	0.6 / 0.8–0.9	F000599
		1.0 / 1.2	F000600
Ss Cu (Fe)	V-groove	0.6 / 0.8–0.9	F000601
		1.0 / 1.2	F000602
MC/FC	V-groove, knurled	1.0 / 1.2	F000603
Al	U-groove	1.0 / 1.2	F000604

#### Wire guide tubes

The table below lists the wire guide tubes available.

Wire guide tubes			
Filler wire material	Filler wire diameter (mm)	Inlet guide tube	Outlet guide tube
Fe (MC/FC)	0.8–0.9	SP007536	SP007454
	1.2	SP007538	SP007456
Ss, Cu (Fe)	0.8–0.9	SP007294	SP007438
	1.2	SP007296	SP007440
MC/FC	1.2	SP007538	SP007456
Al	1.2	SP007296	SP007440

## 5.4 MINARC M WELDING PROGRAM WORK PACKS

Welding program work packs include a set of standard welding programs to allow welding with e.g. automatic 1-MIG and pulse processes. For more information, contact your local Kemppi dealer or go to [Kemppi.com](http://Kemppi.com).

### 1-MIG work pack:

Welding program	Process	Wire material	Wire diameter	Shielding gas	Description
A00	1-MIG	AlMg5	0.9	Ar	Standard
A01	1-MIG	AlMg5	1.0	Ar	Standard
A02	1-MIG	AlMg5	1.2	Ar	Standard
A10	1-MIG	AlSi5	0.9	Ar	Standard
A11	1-MIG	AlSi5	1.0	Ar	Standard
A12	1-MIG	AlSi5	1.2	Ar	Standard
C01	1-MIG	CuSi3	0.8	Ar	Standard: Brazing
C02	1-MIG	CuSi3	0.9	Ar	Standard: Brazing
C03	1-MIG	CuSi3	1.0	Ar	Standard: Brazing
F00	1-MIG	Fe	0.6	Ar+18%CO2	Standard
F01	1-MIG	Fe	0.8	Ar+18%CO2	Standard
F02	1-MIG	Fe	0.9	Ar+18%CO2	Standard
F03	1-MIG	Fe	1.0	Ar+18%CO2	Standard
F10	1-MIG	Fe	0.6	Ar+8%CO2	Standard
F11	1-MIG	Fe	0.8	Ar+8%CO2	Standard
F12	1-MIG	Fe	0.9	Ar+8%CO2	Standard
F13	1-MIG	Fe	1.0	Ar+8%CO2	Standard
F20	1-MIG	Fe	0.6	CO2	Standard
F21	1-MIG	Fe	0.8	CO2	Standard
F22	1-MIG	Fe	0.9	CO2	Standard
F23	1-MIG	Fe	1.0	CO2	Standard
F50	1-MIG	Fe	0.6	Ar+25%CO2	Standard
F51	1-MIG	Fe	0.8	Ar+25%CO2	Standard
F52	1-MIG	Fe	0.9	Ar+25%CO2	Standard
F53	1-MIG	Fe	1.0	Ar+25%CO2	Standard
R03	1-MIG	Fe Rutil	1.0	Ar+18%CO2	Standard
R04	1-MIG	Fe Rutil	1.2	Ar+18%CO2	Standard
R51	1-MIG	Fe	0.8	-	InnerShield
R52	1-MIG	Fe	0.9	-	InnerShield
R55	1-MIG	Fe	1.1	-	InnerShield
S01	1-MIG	Ss	0.8	Ar+2%CO2	Standard
S02	1-MIG	Ss	0.9	Ar+2%CO2	Standard

---

S03	1-MIG	Ss	1.0	Ar+2%CO2	Standard
-----	-------	----	-----	----------	----------

---

**Pulse work pack (Minarc M 223P, 220–240 V only):**

The Pulse work pack includes also all 1-MIG work pack welding programs.







Welding program	Process	Wire material	Wire diameter	Shielding gas	Description
A00	Pulse	AlMg5	0.9	Ar	Standard
A01	Pulse	AlMg5	1.0	Ar	Standard
A02	Pulse	AlMg5	1.2	Ar	Standard
A10	Pulse	AlSi5	0.9	Ar	Standard
A11	Pulse	AlSi5	1.0	Ar	Standard
A12	Pulse	AlSi5	1.2	Ar	Standard
C01	Pulse	CuSi3	0.8	Ar	Standard: Brazing
C02	Pulse	CuSi3	0.9	Ar	Standard: Brazing
C03	Pulse	CuSi3	1.0	Ar	Standard: Brazing
F11	Pulse	Fe	0.8	Ar+8%CO2	Standard
F12	Pulse	Fe	0.9	Ar+8%CO2	Standard
F13	Pulse	Fe	1.0	Ar+8%CO2	Standard
S01	Pulse	Ss	0.8	Ar+2%CO2	Standard
S02	Pulse	Ss	0.9	Ar+2%CO2	Standard
S03	Pulse	Ss	1.0	Ar+2%CO2	Standard

## 5.5 MINARC M ORDERING INFO



For ordering information and optional accessories, refer to [Kemppi.com](https://www.kemppi.com).

## 5.6 MINARC M CONTROL PANEL SYMBOLS AND ICONS SUMMARY



*Control panel button functions:*

	Save memory channel (long press)
	Change memory channel
	MIG welding process selection
	Wire inch (press and hold)
	Trigger logic selection
	Material selection
	Welding parameters
	Gas test



*MIG welding processes:*



	Manual MIG process
	Automatic MIG process (1-MIG)
	Pulse MIG process

*Material selection (1-MIG and Pulse MIG):*









	Filler wire material
	Filler wire diameter
	Shielding gas

*Device settings:*







	Trigger logic 2T
	Trigger logic 4T

	Safety lock
	Terminal voltage
	Arc voltage

*Welding parameters and memory channels:*

	Wire feed (speed)
	Pulse current
	Dynamics
	Fine tuning
	Hot start
	Crater fill
	Post current
	Memory channel (selected and saved)
	Work channel (selected and not saved)

*Warning and caution indicators:*

	Warning: This symbol indicates an error or fault that requires attention, but doesn't prevent welding
	Error: This symbol indicates an error or fault that prevents welding and require immediate action
	Error or fault with power source
	Error or fault with wire feeder
	Overheating error
	Error (error code is shown together with this text)